



## X2-DXX-80

### 10Gbps DWDM X2 ZR Transceiver

#### Features

- X2 MSA Compliant
- 70-PIN connector
- SC duplex receptacle package
- XAU1 4x3.125Gb/s and TX/RX 10Gb/s data rate
- Wavelength selectable to C-band ITU-T grid wavelengths
- Cooled EA-DFB/APD
- Power supply: +5.0 V, +3.3 V, APS:+1.2 V
- Power Dissipation 4W Maximum
- 0°C to 70°C Operating Case Temperature
- Digital Diagnostic Monitoring
- Management and control with MDIO 2-wire bus
- XAU1 electrical interface 4 x 3.125Gb/s Ethernet
- 80km ZR 10GBE
- RoHS compliant and lead free

#### Applications

- 10 Gb/s Ethernet transmission systems

#### Absolute Maximum Ratings

Parameter	Symbol	Min	Max	Unit
Supply Voltage+5V	Vcc5	0	6.0	V
Supply Voltage_3.3V	Vcc3	0	4	V
Supply Voltage APS	Vaps	0	2	V
Storage Temperature	Tst	-20	85	°C
Optical Input Received Power	PIN	-	-7	dBm



## Operating Conditions

Parameter	Symbol	Min	Typical	Max	Unit
Operating Case temperature	Tca	0	-	70	°C
Supply Voltage+5V	Vcc5	4.75	5	5.25	V
Supply Current+5V	Icc5			500	mA
Supply Voltage_3.3V	VCC3	3.14	3.3	3.47	V
Supply Current+3.3V	Icc3			1000	mA
Supply Voltage APS	Vaps	1.14	1.2	1.26	V
Supply Current APS	Iaps			1100	mA
Module Power Dissipation	Pm	-		4	W

## Transmitter Specifications – Optical

Parameter	Symbol	Min	Typical	Max	Unit
Center Wavelength (SOL)△	$\lambda_c$	$\lambda_c-0.05$	ITU-T grid Wavelengths	$\lambda_c+0.05$	nm
Center Wavelength (EOL)▲	$\lambda_c$	$\lambda_c-0.1$	ITU-T grid Wavelengths	$\lambda_c+0.1$	nm
Optical Transmit Power	Po	-1		3	dBm
Optical Transmit Power (disabled)	Ptx-dis	-	-	-40	dBm
Extinction Ratio	ER	9		-	dB
Side Mode Suppression Ratio	SMSR	30	-	-	dB
Eye Mask	IEEE 802.3ae Compliant				

△Laser- Start of Life

▲Laser End of life

## Transmitter Specifications – Electrical

Parameter	Symbol	Min	Typical	Max	Unit
Data Rate (TXLINE0-3)	TX-xaui	-	3125	-	Mbps
Differential impedance	Zo	80	100	120	$\Omega$
Differential Input Amplitude	Vin P-P	160	-	2000	mVpp
Input Rise/Fall	TR / TF	60	-	130	ps
Differential Impedance of Zin	Zin	-	100	-	ohm



## Receiver Specifications – Optical

Parameter	Symbol	Min	Typical	Max	Unit
Received power	Rpo	-24	-	-7	dBm
Maximum Input Power	RX-overload	-7	-	-	dBm
Path Penalty at 1600 ps/nm @ 10.3Gb/s	DP			3	dB
Input Operating Wavelength	$\lambda$	1260	-	1565	nm
Reflectance	Rrx	-	-	-27	dB

## Receiver Specifications – Electrical

Parameter	Symbol	Min	Typical	Max	Unit
Data Rate (TXLINE0-3)	RX-xaui		3125		Mbps
Supply Voltage	VccRX	3.13	3.3	3.47	V
Differential Output Amplitude	Vout P-P	800	-	1600	mV
Rise/Fall Time	Tr / Tf	50	-	90	ps
Differential Impedance of Zout	Zout	-	100	-	ohm

## Signal Specifications – Electrical

Parameter	Symbol	Min	Typ	Max	Units
1.2 V CMOS					
Input High Voltage	VIL(MAX)	-	-	0.36	V
Input Low Voltage	VIH(MIN)	0.84	-	1.25	V
Capacitance		-	-	320	pF
Pull Up Resistance	Rpull	10k	-	22k	ohm
MDIO I/O					
Output Low Voltage	VOL	-0.3	-	0.2	V
Output Low Current	IOL	-	-	4	mA
Input High Voltage	VIH	0.84	-	1.5	V
Input Low Voltage	VIL	-0.3	-	0.36	V
Pull-up Supply Voltage	VPULL	1.14	1.2	1.26	
Input Capacitance	CIN	-	-	10	Pf
Load Capacitance	CLOD	-	-	470	Pf
External Pull-up Resistance	EPULL	200	-	-	Ohm



**Table 3: Digital Diagnostic Monitoring Accuracy**

Parameter	Accuracy	Unit
Temperature	± 5	°C
Bias Current	± 10	%
TX Power	± 3	DBm
RX Power	± 3	DBm

**Pin Definitions**

Pin No	Name	Dir	Function	Notes
1	GND		Electrical Ground	1
2	GND		Electrical Ground	1
3	GND		Electrical Ground	1
4	5.0V		Power	2
5	3.3V		Power	2
6	3.3V		Power	2
7	APS =1.2V		Adaptive Power Supply	2
8	APS =1.2V		Adaptive Power Supply	2
9	LASI		Open Drain Compatible. 10K-22K pull up on host. Logic High: Normal Operation Logic Low: LASI Asserted	4
10	RESET	I	Open Drain compatible. 10-22K pull-up on transceiver Logic high = Normal operation Logic low = Reset Minimum reset assert time 1 ms	4
11	VEND SPECIFIC		Vendor Specific Pin. Leave unconnected when not in use.	8
12	TX ON/OFF	I	Open Drain compatible. 10-22K pull-up on transceiver Logic high = Transmitter On (capable) Logic low = Transmitter Off (always)	4
13	RESERVED		Reserved	4
14	MOD DETECT	O	Pulled low inside module through 1k	
15	VEND SPECIFIC		Vendor Specific Pin. Leave unconnected when not in use.	8
16	VEND SPECIFIC		Vendor Specific Pin. Leave unconnected when not in use.	8
17	MDIO	I/O	Management Data IO	4, 5
18	MDC	I	Management Data Clock	4, 5
19	PRTAD4	I	Port Address Bit 4 (Low = 0)	4
20	PRTAD3	I	Port Address Bit 3 (Low = 0)	4
21	PRTAD2	I	Port Address Bit 2 (Low = 0)	4
22	PRTAD1	I	Port Address Bit 1 (Low = 0)	4
23	PRTAD0	I	Port Address Bit 0 (Low = 0)	4
24	VEND SPECIFIC		Vendor Specific Pin. Leave unconnected when not in use.	8
25	APS SET		Feedback input for APS	
26	RESERVED		Reserved for Avalanche Photodiode use.	8
27	APS SENSE		APS Sense Connection	
28	APS =1.2V		Adaptive Power Supply	2



29	APS =1.2V		Adaptive Power Supply	2
30	3.3V		Power	2
31	3.3V		Power	2
32	5.0V		Power	2
33	GND		Electrical Ground	1
34	GND		Electrical Ground	1
35	GND		Electrical Ground	1
36	GND		Electrical Ground	1
37	GND		Electrical Ground	1
38	RESERVED		Reserved	
39	RESERVED		Reserved	
40	GND		Electrical Ground	1
41	RX LANE0+	O	Module XAUI Output Lane 0+	7
42	RX LANE0-	O	Module XAUI Output Lane 0-	7
43	GND		Electrical Ground	1
44	RX LANE1+	O	Module XAUI Output Lane 1+	7
45	RX LANE1-	O	Module XAUI Output Lane 1-	7
46	GND		Electrical Ground	1
47	RX LANE2+	O	Module XAUI Output Lane 2+	7
48	RX LANE2-	O	Module XAUI Output Lane 2-	7
49	GND		Electrical Ground	1
50	RX LANE3+	O	Module XAUI Output Lane 3+	7
51	RX LANE3-	O	Module XAUI Output Lane 3-	7
52	GND		Electrical Ground	1
53	GND		Electrical Ground	1
54	GND		Electrical Ground	1
55	TX LANE0+	I	Module XAUI Input Lane 0+	7
56	TX LANE0-	I	Module XAUI Input Lane 0-	7
57	GND		Electrical Ground	1
58	TX LANE1+	I	Module XAUI Input Lane 1+	7
59	TX LANE1-	I	Module XAUI Input Lane 1-	7
60	GND		Electrical Ground	1
61	TX LANE2+	I	Module XAUI Input Lane 2+	7
62	TX LANE2-	I	Module XAUI Input Lane 2-	7
63	GND		Electrical Ground	1
64	TX LANE3+	I	Module XAUI Input Lane 3+	7
65	TX LANE3-	I	Module XAUI Input Lane 3-	7
66	GND		Electrical Ground	1
67	RESERVED		Reserved	
68	RESERVED		Reserved	
69	GND		Electrical Ground	1
70	GND		Electrical Ground	1

**Notes:**

- 1) Ground connections are common for TX and RX.
- 2) All connector contacts are rated at 0.5A nominal.
- 4) 1.2V CMOS compatible.
- 5) MDIO and MDC timing must comply with IEEE802.3ae, Clause 45.3
- 7) XAUI output characteristics should comply with IEEE802.3ae Clause 47.
- 8) Transceivers will be MSA compliant when no signals are present on the vendor specific pins.



## C-band $\lambda$ c Wavelength Guide

ITU Channel Product Code	Frequency(THz)	Wavelength	ITU Channel Product Code	Frequency(THz)	Wavelength
17	191.7	1563.86	40	194.0	1545.32
18	191.8	1563.05	41	194.1	1544.53
19	191.9	1562.23	42	194.2	1543.73
20	192.0	1561.42	43	194.3	1542.94
21	192.1	1560.61	44	194.4	1542.14
22	192.2	1559.79	45	194.5	1541.35
23	192.3	1558.98	46	194.6	1540.56
24	192.4	1558.17	47	194.7	1539.77
25	192.5	1557.36	48	194.8	1538.98
26	192.6	1556.55	49	194.9	1538.19
27	192.7	1555.75	50	195.0	1537.40
28	192.8	1554.94	51	195.1	1536.61
29	192.9	1554.13	52	195.2	1535.82
30	193.0	1553.33	53	195.3	1535.04
31	193.1	1552.52	54	195.4	1534.25
32	193.2	1551.72	55	195.5	1533.47
33	193.3	1550.92	56	195.6	1532.68
34	193.4	1550.12	57	195.7	1531.90
35	193.5	1549.32	58	195.8	1531.12
36	193.6	1548.51	59	195.9	1530.33
37	193.7	1547.72	60	196.0	1529.55
38	193.8	1546.92	61	196.1	1528.77
39	193.9	1546.12			

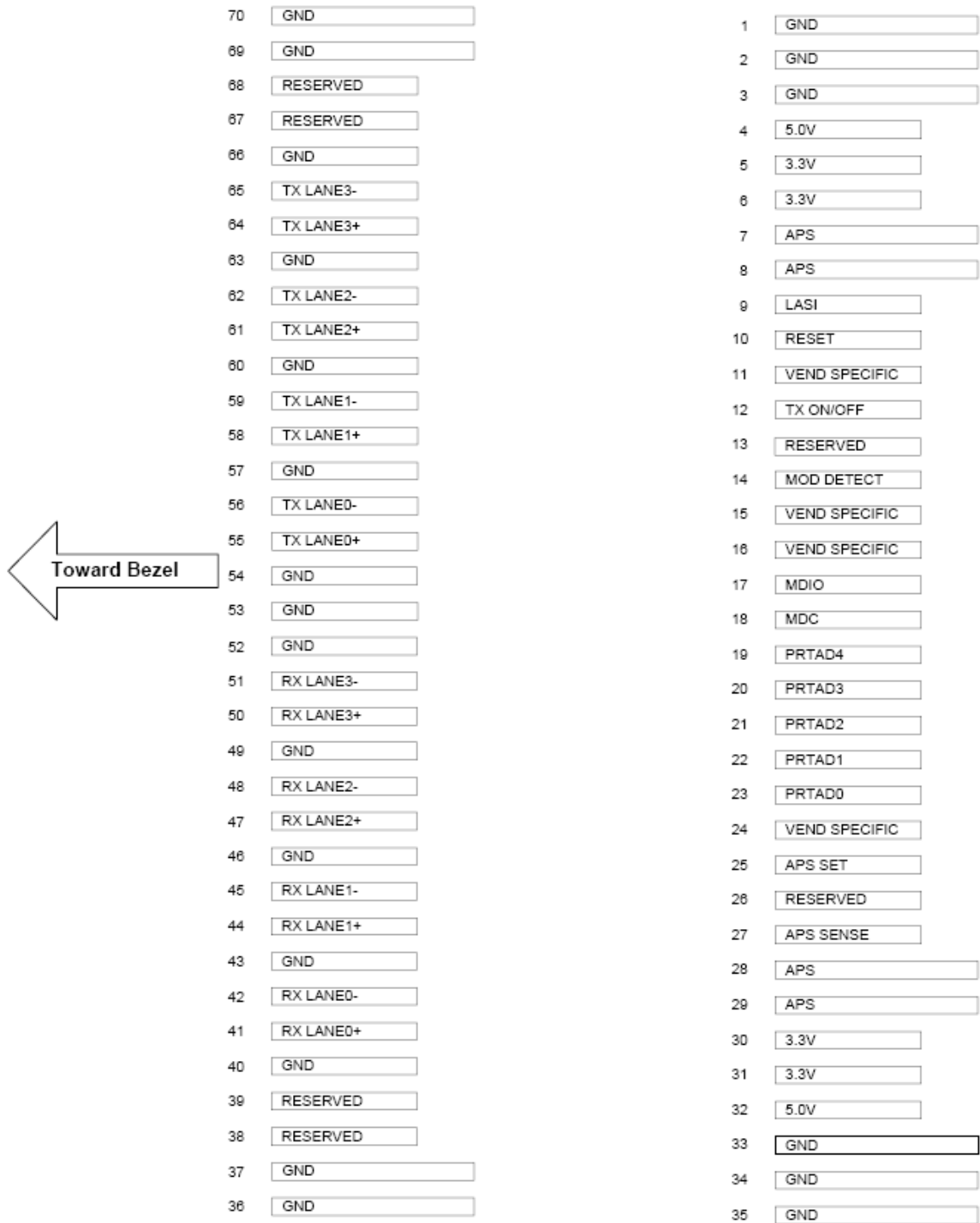
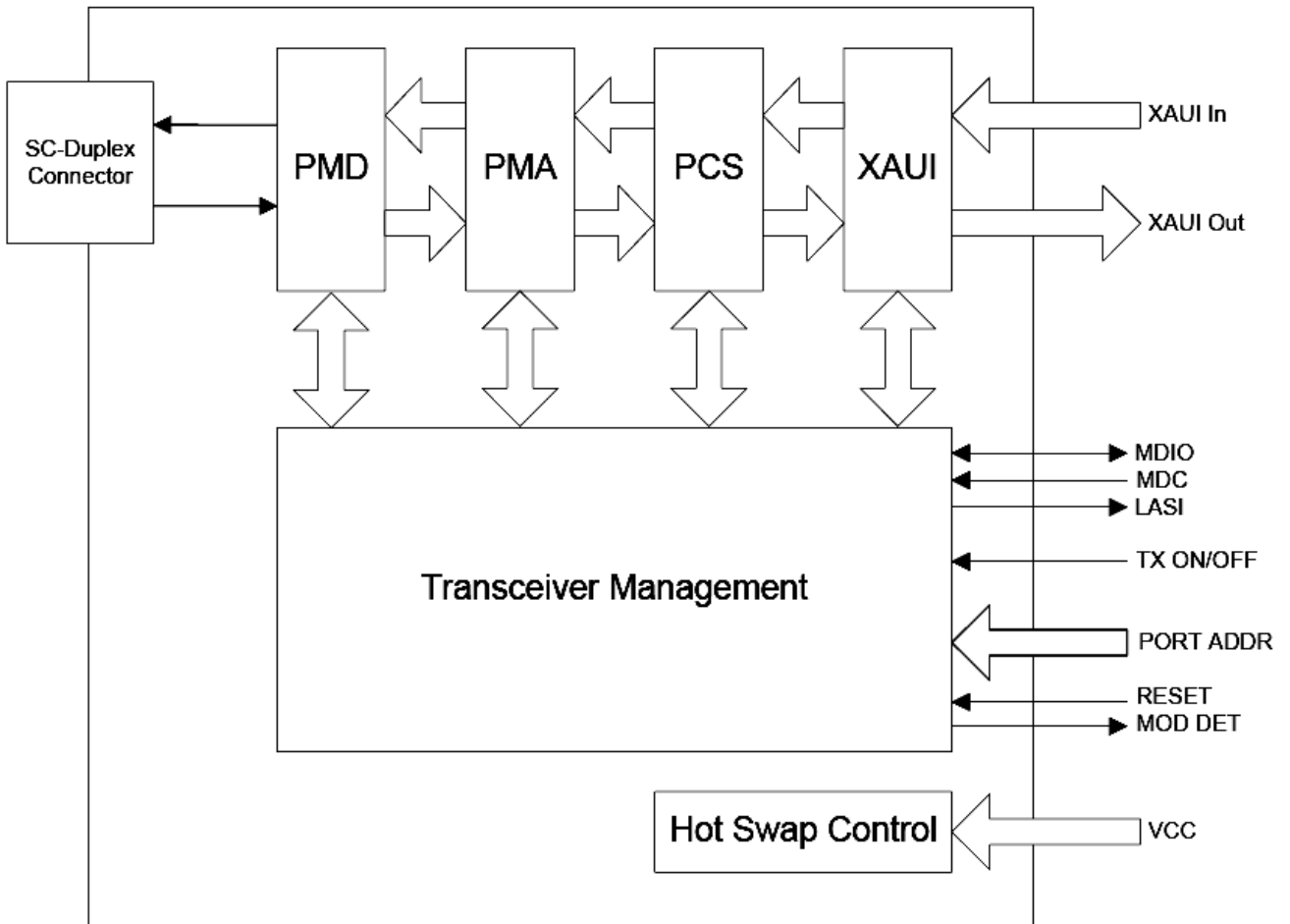
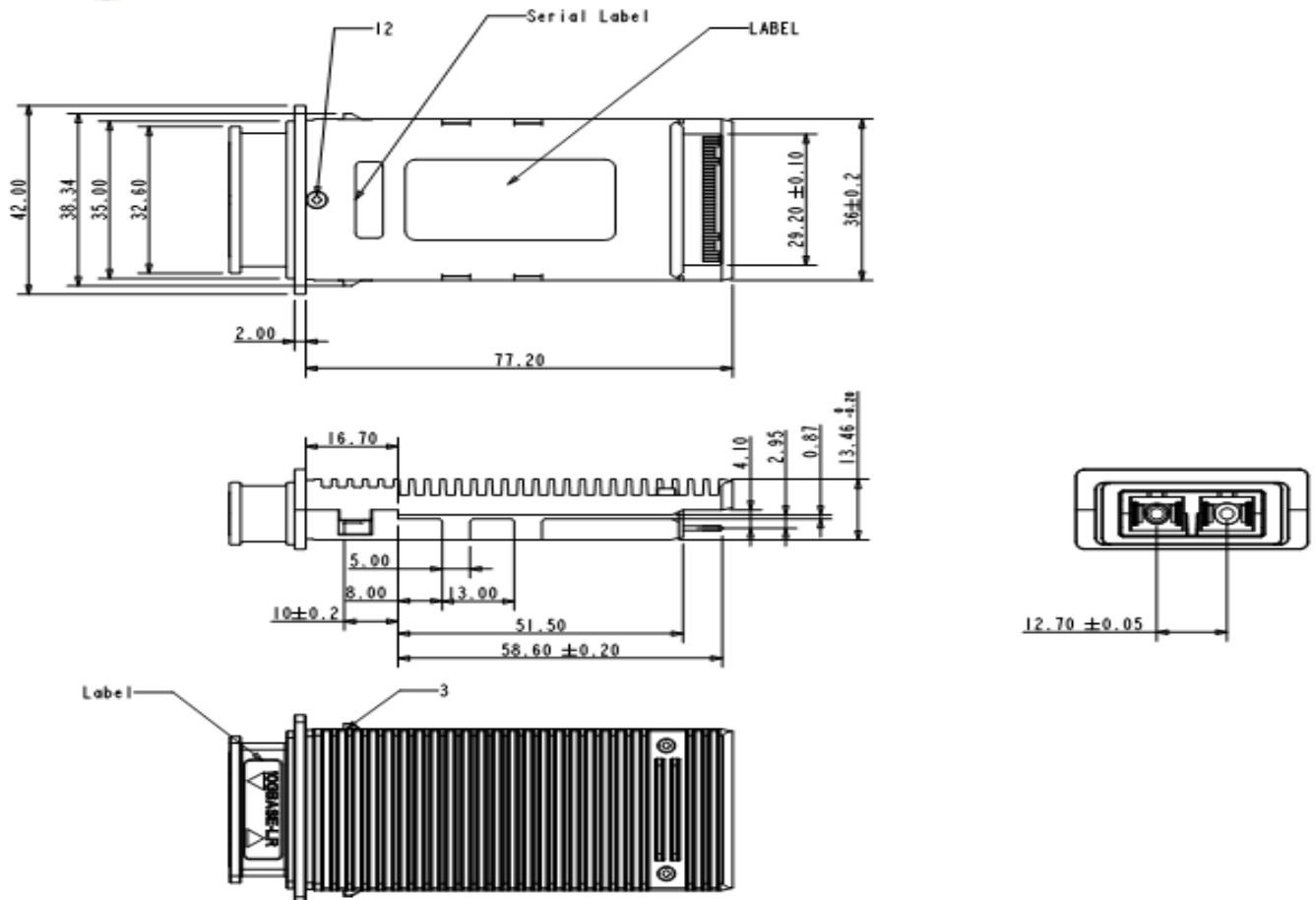

Figure1.Electrical Pin-out Details



**Figure2.** Functional Diagram of Typical X2 Style Transceiver



Dimensions in mm

**Figure3.** Mechanical Dimensions

### Ordering information

Part Number	Product Description
X2-DXX-80	DWDM X2, 80km(ZR), 0°C ~ 70°C, Cooled EA-DFB/APD
XX=17~61	(ITU Channel C-band)

E-mail: [sales@accsystems.fi](mailto:sales@accsystems.fi)

Web : <http://www.accsystems.fi>