

# 155Mbps ATM-Multimode Transceiver

SFP, Duplex LC Connector, 1310nm FP LD for Multimode Fiber, RoHS Compliant



## Applications

- Fast Ethernet
- FDDI
- ATM/SONET OC-3/SDH STM-1
- Single mode fiber links
- Optical-Electrical Interface Conversion

## Features

- 1310nm LED/FP LD
- Data Rate: 155Mbps, NRZ
- Single +3.3V Power Supply
- RoHS Compliant and Lead-free
- AC/AC Differential Electrical Interface
- Compliant with Multi-Source Agreement (MSA) Small Form Factor Pluggable (SFP)
- Compliant with SFF-8472 Digital Diagnostic Monitoring Interface ( optional )
- Duplex LC Connector
- Compliance with 100Base-FX of IEEE802.3u Standard
- Compliance with FDDI PMD Standard
- Compliance with ATM Standard

## Description

The AB-FE-FX-x series from ACC Systems Oy is the high performance and cost-effective module for serial optical data communication applications specified for multimode of 155 Mb/s. It operates with +3.3V power supply. The module is intended for multimode fiber, operates at a nominal wavelength of 1310nm and complies with Multi-Source Agreement (MSA) Small Form Factor Pluggable (SFP). Each module is integrated digital diagnostics functions via an I<sup>2</sup>C serial interface ( optional ).

The module is a duplex LC connector transceiver designed to provide an ATM/SONET OC-3/SDH STM-1 compliant link for 155 Mb/s intermediate reach applications. The characteristics are performed in accordance with Telcordia Specification GR-468-CORE.

## EMC

Most equipment utilizing high-speed transceivers will be required to meet the following requirements:

- 1) FCC in the United States
- 2) CENELEC EN55022 (CISPR 22) in Europe

To assist the customer in managing the overall equipment EMC performance, the transceivers have been designed to satisfy FCC class B limits and provide good immunity to radio-frequency electromagnetic fields.

## Eye Safety

The transceivers have been designed to meet Class 1 eye safety and comply with EN 60825-1.

# 155Mbps ATM-Multimode Transceiver



## Product Information

Model Number	Operating Temperature. & Monitor Function	Distance	LD Type & Wavelength	Output Power	Sensitivity
<i>AB-FE-FX</i>	<i>0~70 °C</i>				
<i>AB-FE-FX-D</i>	<i>0~70 °C with DOM</i>	2 km	1310 nm	-19 ~ -14 dBm	≤ -32 dBm
<i>AB-FE-FX-T</i>	<i>-40~85°C</i>				
<i>AB-FE-FX-DT</i>	<i>-40~85°C with DOM</i>				

## ABSOLUTE MAX RATINGS

PARAMETER	SYMBOL	MIN	MAX	UNIT	NOTE
Storage Temperature	T <sub>S</sub>	-40	85	°C	
Supply Voltage	V <sub>CC</sub>	0	6	V	
Data Input Voltage	---	0	V <sub>cc</sub>	V	

## OPERATING CONDITIONS

PARAMETER	SYMBOL	MIN.	TYP.	MAX.	UNIT	NOTE
Supply Voltage	V <sub>CC</sub>	3.1		3.5	V	
Data Input Voltage Swing	V <sub>ID</sub>	400		1600	mV	

## ELECTRICAL CHARACTERISTICS

PARAMETER	SYMBOL	MIN	MAX	UNIT	NOTE
<b>Transmitter</b>					
Transmitter Supply Current	I <sub>CC</sub> T		200	mA	
Tx Disable Input Voltage - Low	V <sub>IL</sub>	0	0.8	V	
Tx Disable Input Voltage - High	V <sub>IH</sub>	2.0	V <sub>cc</sub>	V	
Tx Fault Output Voltage - Low	V <sub>OL</sub>	0	0.8	V	
Tx Fault Output Voltage - High	V <sub>OH</sub>	2.0	V <sub>cc</sub>	V	
<b>Receiver</b>					
Receiver Supply Current	I <sub>CC</sub> R		100	mA	
Receiver Data Output Differential Voltage	V <sub>OD</sub>	0.4	1.3	V	
Rx LOS Output Voltage - Low	V <sub>OL</sub>	0	0.8	V	
Rx LOS Output Voltage - High	V <sub>OH</sub>	2.0	V <sub>cc</sub>	V	
MOD_DEF (1) , MOD_DEF (2) - Low	V <sub>IL</sub>	-0.6	V <sub>cc</sub> × 0.3	V	
MOD_DEF (1) , MOD_DEF (2) - High	V <sub>IH</sub>	V <sub>cc</sub> × 0.7	V <sub>cc</sub> + 0.5	V	

## TRANSMITTER ELECTRO-OPTICAL CHARACTERISTICS

PARAMETER	SYMBOL	MIN	TYP.	MAX	UNIT	NOTE
Optical Output Power	P <sub>o</sub>	-19	-17	-14	dBm	1
Extinction Ratio	ER	8.2			dB	
Center Wavelength	λ <sub>c</sub>	1270		1360	nm	
Spectral Width (RMS)	Δ λ			200	nm	
Optical Rise time ( 10%-90% )	t <sub>r</sub>			3.0	ns p-p	
Optical Fall time ( 10%-90% )	t <sub>f</sub>			3.0	ns p-p	
Output Eye		Compliant with ITU recommendation G.957				

# 155Mbps ATM-Multimode Transceiver

## RECEIVER ELECTRO-OPTICAL CHARACTERISTICS

PARAMETER	SYMBOL	MIN	TYP.	MAX	UNIT	NOTE
Maximum Input Optical Power	$P_{max}$	-14			dBm	2
Receiver Sensitivity	$P_{min}$			-32	dBm	2
Operating Wavelength	$\lambda$	1100		1600	nm	
Loss of Signal - Asserted	$P_A$	-45			dBm	
Loss of Signal - Deasserted	$P_D$	$P_A + 0.5$		-31	dBm	
Loss of Signal - Hysteresis	$P_D - P_A$	0.5		4	dB	

### Notes:

1. Measured average power coupled into 62.5/125  $\mu$  m, 0.275 NA graded index multimode fiber.
2. Measured with  $2^{23}-1$  PRBS at BER <  $10^{-10}$

## TIMING CHARACTERISTICS

PARAMETER	SYMBOL	MIN	TYP.	MAX	UNIT	NOTE
TX_DISABLE Assert Time	$t_{off}$			10	$\mu$ s	
TX_DISABLE Negate Time	$t_{on}$			1	ms	
Time to initialize, include reset of TX_FAULT	$t_{init}$			300	ms	
TX_FAULT from fault to assertion	$t_{fault}$			100	$\mu$ s	
TX_DISABLE time to start reset	$t_{reset}$	10			$\mu$ s	
Receiver Loss of Signal Assert Time (off to on)	$t_{A,RX\_LOS}$			100	$\mu$ s	
Receiver Loss of Signal Assert Time (on to off)	$t_{D,RX\_LOS}$			100	$\mu$ s	

## BLOCK DIAGRAM OF TRANSCEIVER

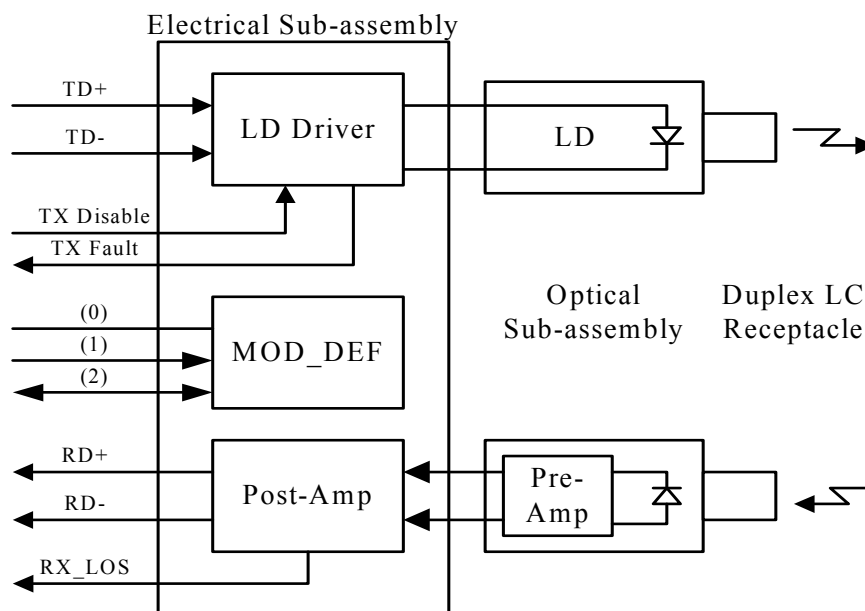

# 155Mbps ATM-Multimode Transceiver

## PIN OUT DIAGRAM OF TRANSCEIVER

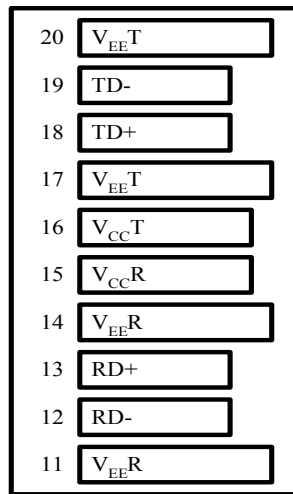

Top of Board

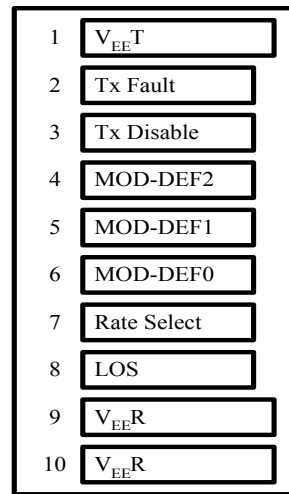

Bottom of Board (As Viewed through Top of Board)

## PIN OUT TABLE

Pin	Symbol	Functional Description
1	VeeT	Transmitter Ground
2	TX Fault	Transmitter Fault Indication
3	TX Disable	Transmitter Disable – Module disables on high or open
4	MOD-DEF(2)	Module Definition 2 – Two wire serial ID interface
5	MOD-DEF(1)	Module Definition 1 – Two wire serial ID interface
6	MOD-DEF(0)	Module Definition 0 – Grounded in module
7	Rate Select	Not Connected
8	LOS	Loss of Signal
9	VeeR	Receiver Ground
10	VeeR	Receiver Ground
11	VeeR	Receiver Ground
12	RD-	Inverse Received Data Out
13	RD+	Received Data Out
14	VeeR	Receiver Ground
15	VccR	Receiver Power
16	VccT	Transmitter Power
17	VeeT	Transmitter Ground
18	TD+	Transmitter Data In
19	TD-	Inverse Transmitter Data In
20	VeeT	Transmitter Ground

# 155Mbps ATM-Multimode Transceiver

## RECOMMENDED CIRCUIT SCHEMATIC

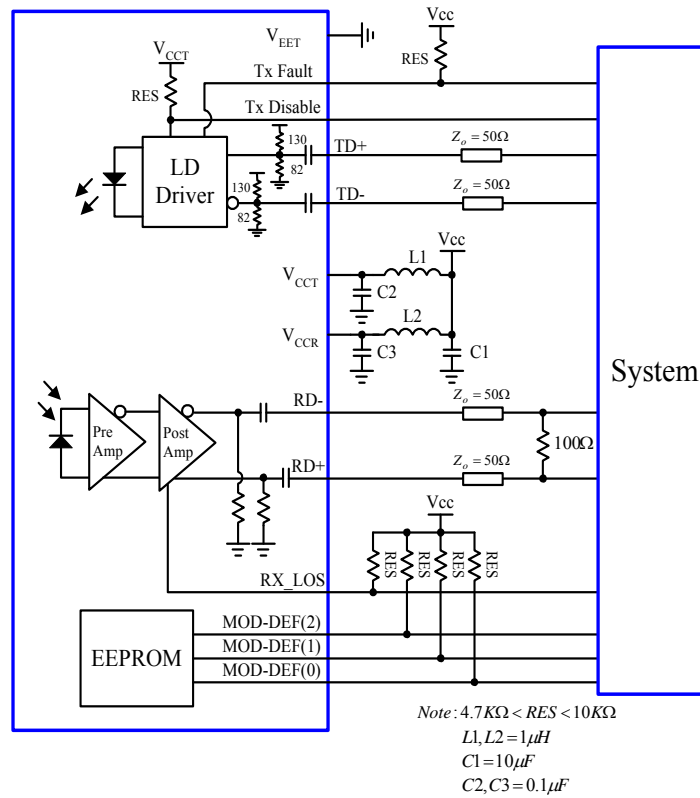

## MECHANICAL DIMENSIONS

Units in mm

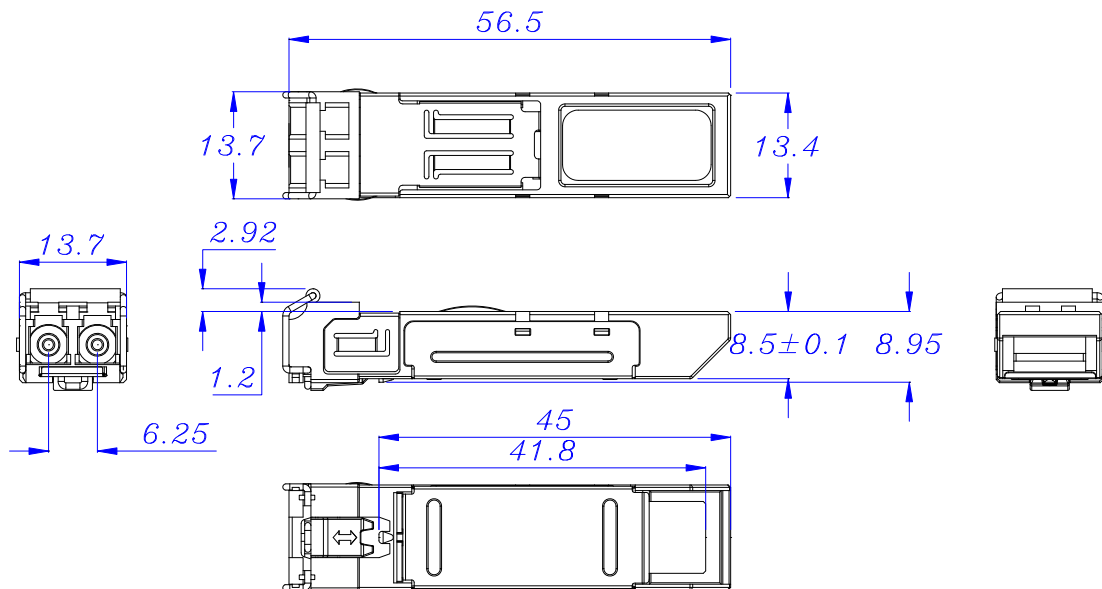

All dimensions are  $\pm 0.2\text{mm}$  unless otherwise specified.

### Claim:

ACC Systems Oy reserves the right to make changes in the specification described hereinafter without prior notice.