

## 1.25 Gigabit Ethernet-Single Mode Transceiver

SFP, Duplex LC Connector, CWDM LD for Single Mode Fiber, RoHS Compliant

Power Budget 30dB

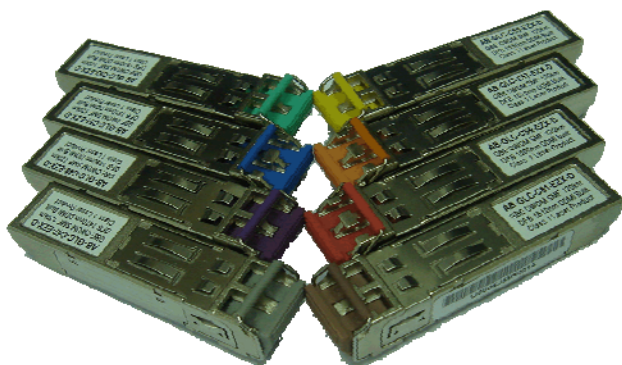

### Features

- CWDM 8 wavelengths Transmitter
- APD Receiver
- Data Rate: 1.25Gbps, NRZ
- Single +3.3V Power Supply
- RoHS Compliant and Lead-free
- AC/AC Differential Electrical Interface
- Compliant with Multi-Source Agreement (MSA) Small Form Factor Pluggable (SFP)
- Compliant with SFF-8472 Digital Diagnostic Monitoring Interface ( optional )
- Duplex LC Connector
- Compliance with specifications for IEEE-802.3z Gigabit Ethernet at 1.25 Gbps
- Compliance with ANSI specifications for Fibre Channel applications at 1.06 Gbps
- Eye Safety  
Designed to meet Laser Class 1 comply with EN60825-1

### Applications

- CWDM
- Gigabit Ethernet Links
- Fibre Channel Links at 1.06 Gbps
- High Speed Backplane Interconnects
- Switched Backbones

### Description

The AB-GLC-Cxx-EZX-x series from ACC Systems Oy are the high performance and cost-effective modules for serial optical data communication applications specified for single mode of 1.25 Gb/s. It operates with +3.3V power supply. The module is intended for single mode fiber, operates at a nominal wavelength of CWDM and complies with Multi-Source Agreement (MSA) Small Form Factor Pluggable (SFP). Each module is integrated digital diagnostics functions via an I<sup>2</sup>C serial interface ( optional ).

The module is a duplex LC connector transceiver designed for use in Gigabit Ethernet applications and to provide IEEE-802.3z compliant link for 1.25Gb/s long reach applications. The characteristics are performed in accordance with ITU-T G.694.2 and G.695.

### EMC

Most equipment utilizing high-speed transceivers will be required to meet the following requirements:

- 1) FCC in the United States
- 2) CENELEC EN55022 (CISPR 22) in Europe

To assist the customer in managing the overall equipment EMC performance, the transceivers have been designed to satisfy FCC class B limits and provide good immunity to radio-frequency electromagnetic fields.

### Eye Safety

The transceivers have been designed to meet Class 1 eye safety and comply with EN 60825-1.

# 1.25 Gigabit Ethernet-Single Mode Transceiver



## Product Information

Model Number	Wavelength	Latch Color	Operating Temperature & Monitor Function	Distance	Output Power	Sensitivity
AB-GLC-C47-EZX	1470 nm	Gray	0~70 °C	120 km	0 ~ +5 dBm	≤-30 dBm
AB-GLC-C49-EZX	1490 nm	Violet				
AB-GLC-C51-EZX	1510 nm	Blue				
AB-GLC-C53-EZX	1530 nm	Green				
AB-GLC-C55-EZX	1550 nm	Yellow				
AB-GLC-C57-EZX	1570 nm	Orange				
AB-GLC-C59-EZX	1590 nm	Red				
AB-GLC-C61-EZX	1610 nm	Brown				
AB-GLC-C47-EZX-D	1470 nm	Gray	0~70 °C with DOM	120 km	0 ~ +5 dBm	≤-30 dBm
AB-GLC-C49-EZX-D	1490 nm	Violet				
AB-GLC-C51-EZX-D	1510 nm	Blue				
AB-GLC-C53-EZX-D	1530 nm	Green				
AB-GLC-C55-EZX-D	1550 nm	Yellow				
AB-GLC-C57-EZX-D	1570 nm	Orange				
AB-GLC-C59-EZX-D	1590 nm	Red				
AB-GLC-C61-EZX-D	1610 nm	Brown				
AB-GLC-C47-EZX-T	1470 nm	Gray	-40~85 °C	120 km	0 ~ +5 dBm	≤-30 dBm
AB-GLC-C49-EZX-T	1490 nm	Violet				
AB-GLC-C51-EZX-T	1510 nm	Blue				
AB-GLC-C53-EZX-T	1530 nm	Green				
AB-GLC-C55-EZX-T	1550 nm	Yellow				
AB-GLC-C57-EZX-T	1570 nm	Orange				
AB-GLC-C59-EZX-T	1590 nm	Red				
AB-GLC-C61-EZX-T	1610 nm	Brown				
AB-GLC-C47-EZX-DT	1470 nm	Gray	-40~85 °C with DOM	120 km	0 ~ +5 dBm	≤-30 dBm
AB-GLC-C49-EZX-DT	1490 nm	Violet				
AB-GLC-C51-EZX-DT	1510 nm	Blue				
AB-GLC-C53-EZX-DT	1530 nm	Green				
AB-GLC-C55-EZX-DT	1550 nm	Yellow				
AB-GLC-C57-EZX-DT	1570 nm	Orange				
AB-GLC-C59-EZX-DT	1590 nm	Red				
AB-GLC-C61-EZX-DT	1610 nm	Brown				

## ABSOLUTE MAX RATINGS

PARAMETER	SYMBOL	MIN	MAX	UNIT	NOTE
Storage Temperature	T <sub>S</sub>	-40	85	°C	
Supply Voltage	V <sub>CC</sub>	0	6	V	
Data Input Voltage	---	0	V <sub>CC</sub>	V	
Supply Current	I <sub>S</sub>		300	mA	

## OPERATING CONDITIONS

PARAMETER	SYMBOL	MIN.	TYP.	MAX.	UNIT	NOTE
Supply Voltage	V <sub>CC</sub>	3.1		3.5	V	
Data Input Voltage Swing	V <sub>ID</sub>	300		1860	mV	

# 1.25 Gigabit Ethernet-Single Mode Transceiver



## ELECTRICAL CHARACTERISTICS

PARAMETER	SYMBOL	MIN	MAX	UNIT	NOTE
<b>Transmitter</b>					
Transmitter Supply Current	$I_{\text{CC T}}$		200	mA	
Tx Disable Input Voltage - Low	$V_{\text{IL}}$	0	0.8	V	
Tx Disable Input Voltage - High	$V_{\text{IH}}$	2.0	$V_{\text{CC}}$	V	
Tx Fault Output Voltage - Low	$V_{\text{OL}}$	0	0.8	V	
Tx Fault Output Voltage - High	$V_{\text{OH}}$	2.0	$V_{\text{CC}}$	V	
<b>Receiver</b>					
Receiver Supply Current	$I_{\text{CC R}}$		100	mA	
Receiver Data Output Differential Voltage	$V_{\text{OD}}$	0.4	1.3	V	
Rx LOS Output Voltage - Low	$V_{\text{OL}}$	0	0.8	V	
Rx LOS Output Voltage - High	$V_{\text{OH}}$	2.0	$V_{\text{CC}}$	V	
MOD_DEF (1) , MOD_DEF (2) - Low	$V_{\text{IL}}$	-0.6	$V_{\text{CC}} \times 0.3$	V	
MOD_DEF (1) , MOD_DEF (2) - High	$V_{\text{IH}}$	$V_{\text{CC}} \times 0.7$	$V_{\text{CC}} + 0.5$	V	

## TRANSMITTER ELECTRO-OPTICAL CHARACTERISTICS

PARAMETER	SYMBOL	MIN	TYP.	MAX	UNIT	NOTE	
Optical Output Power	$P_{\text{o}}$	0		5	dBm	1	
Extinction Ratio	ER	9			dB		
Center Wavelength	$\lambda_{\text{c}}$	1464.5	1470	1477.5	nm		
		1484.5	1490	1497.5			
		1504.5	1510	1517.5			
		1524.5	1530	1537.5			
		1544.5	1550	1557.5			
		1564.5	1570	1577.5			
		1584.5	1590	1597.5			
		1604.5	1610	1617.5			
Spectral Width (-20dB)	$\Delta \lambda$			1	nm		
Side Mode Suppression Ratio	SMSR	30			dB		
RIN	RIN			-120	dB/Hz		
Optical Rise time (20%-80%)	$t_{\text{r}}$			260	ps	2	
Optical Fall time (20%-80%)	$t_{\text{f}}$			260	ps	2	
Output Eye		Compliant with IEEE802.3z/D5.0					

## RECEIVER ELECTRO-OPTICAL CHARACTERISTICS

PARAMETER	SYMBOL	MIN	TYP.	MAX	UNIT	NOTE
Maximum Input Optical Power	$P_{\text{max}}$	-8			dBm	3
Minimum Input Optical Power	$P_{\text{min}}$			-30	dBm	3
Operating Wavelength	$\lambda$	1260		1620	nm	
Optical Return Loss	ORL	12			dB	
Receiver Electrical 3dB Upper Cutoff Frequency	---			1500	MHz	
LOS of Signal - Asserted	$P_{\text{A}}$	-42			dBm	
LOS of Signal - Deasserted	$P_{\text{D}}$			-29	dBm	
Loss of Signal -Hysterisis	$P_{\text{D}} - P_{\text{A}}$	0.5			dB	

### Notes:

1. Measured average power coupled into 9/125  $\mu$  m single mode fiber.
2. These are 20-80% values.
3. Measured with 2<sup>7</sup>-1 PRBS at BER<10<sup>-12</sup>

# 1.25 Gigabit Ethernet-Single Mode Transceiver



## TIMING CHARACTERISTICS

PARAMETER	SYMBOL	MIN	TYP.	MAX	UNIT	NOTE
TX_DISABLE Assert Time	$t_{off}$			10	$\mu s$	
TX_DISABLE Negate Time	$t_{on}$			1	ms	
Time to initialize, include reset of TX_FAULT	$t_{init}$			300	ms	
TX_FAULT from fault to assertion	$t_{fault}$			100	$\mu s$	
TX_DISABLE time to start reset	$t_{reset}$	10			$\mu s$	
Receiver Loss of Signal Assert Time (off to on)	$t_{A,RX\_LOS}$			100	$\mu s$	
Receiver Loss of Signal Assert Time (on to off)	$t_{D,RX\_LOS}$			100	$\mu s$	

## BLOCK DIAGRAM OF TRANSCEIVER

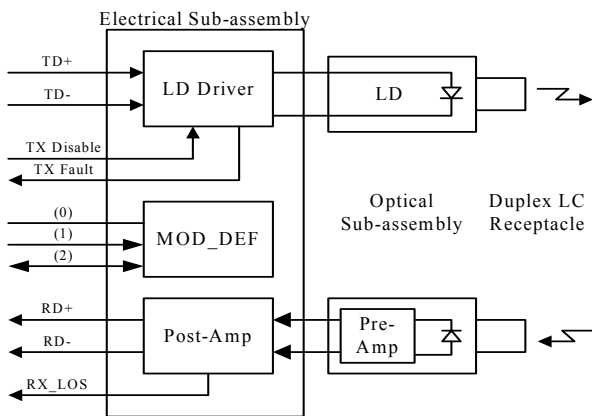

## PIN OUT DIAGRAM OF TRANSCEIVER

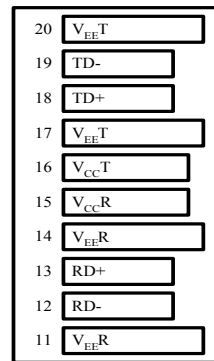

Top of Board

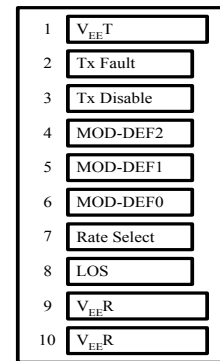

Bottom of Board (As Viewed through Top of Board)

## PIN OUT TABLE

Pin	Symbol	Functional Description
1	VeeT	Transmitter Ground
2	TX Fault	Transmitter Fault Indication
3	TX Disable	Transmitter Disable – Module disables on high or open
4	MOD-DEF(2)	Module Definition 2 – Two wire serial ID interface
5	MOD-DEF(1)	Module Definition 1 – Two wire serial ID interface
6	MOD-DEF(0)	Module Definition 0 – Grounded in module
7	Rate Select	Not Connected
8	LOS	Loss of Signal
9	VeeR	Receiver Ground
10	VeeR	Receiver Ground
11	VeeR	Receiver Ground
12	RD-	Inverse Received Data Out
13	RD+	Received Data Out
14	VeeR	Receiver Ground
15	VccR	Receiver Power
16	VccT	Transmitter Power
17	VeeT	Transmitter Ground
18	TD+	Transmitter Data In
19	TD-	Inverse Transmitter Data In
20	VeeT	Transmitter Ground

# 1.25 Gigabit Ethernet-Single Mode Transceiver



## RECOMMENDED CIRCUIT SCHEMATIC

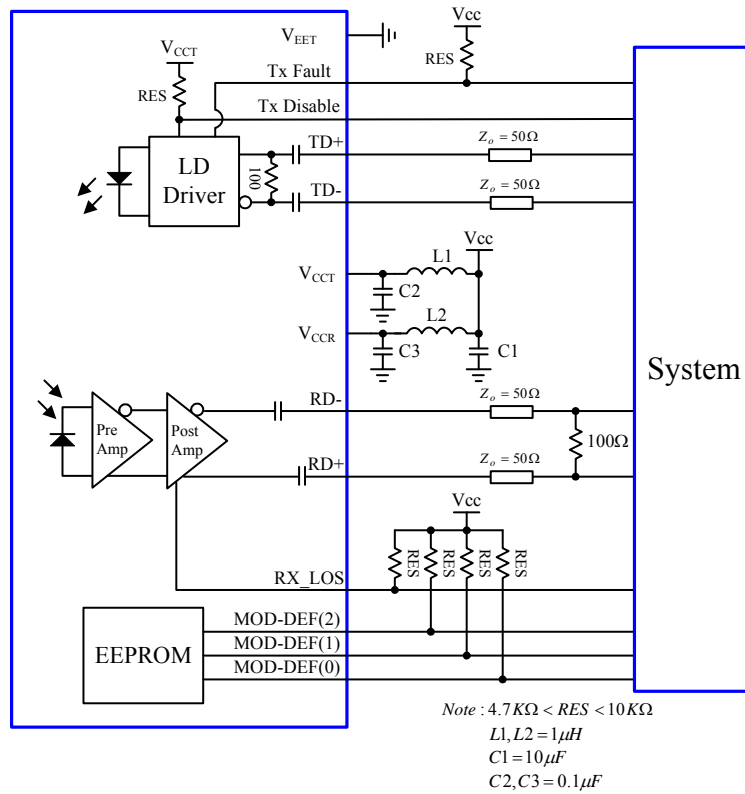

## MECHANICAL DIMENSIONS

Units in mm

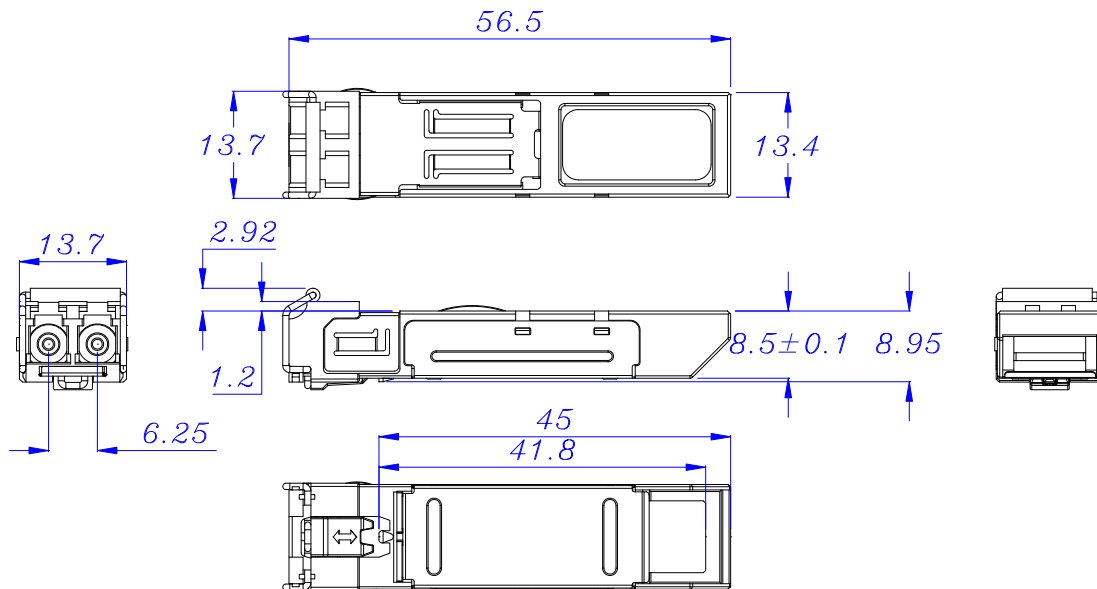

All dimensions are  $\pm 0.2\text{mm}$  unless otherwise specified.

### Claim:

ACC Systems Oy reserves the right to make changes in the specification described hereinafter without prior notice.