

1.25 Gigabit Ethernet-Single Mode Transceiver

SFP, Duplex LC Connector, CWDM LD for Single Mode Fiber, RoHS Compliant

Power Budget 24dB

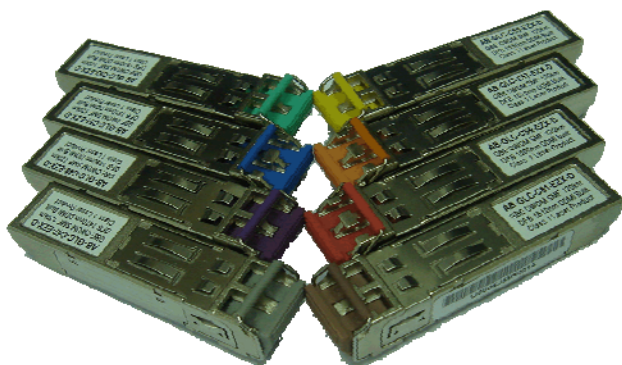

Features

- CWDM 8 wavelengths Transmitter
- Data Rate: 1.25Gbps, NRZ
- Single +3.3V Power Supply
- RoHS Compliant and Lead-free
- AC/AC Differential Electrical Interface
- Compliant with Multi-Source Agreement (MSA) Small Form Factor Pluggable (SFP)
- Compliant with SFF-8472 Digital Diagnostic Monitoring Interface (optional)
- Duplex LC Connector
- Compliance with specifications for IEEE-802.3z Gigabit Ethernet at 1.25 Gbps
- Compliance with ANSI specifications for Fibre Channel applications at 1.06 Gbps
- Eye Safety
Designed to meet Laser Class 1 comply with EN60825-1

Applications

- CWDM
- Gigabit Ethernet Links
- Fibre Channel Links at 1.06 Gbps
- High Speed Backplane Interconnects
- Switched Backbones

Description

The AB-GLC-Cxx-ZX-x series from ACC Systems Oy are the high performance and cost-effective modules for serial optical data communication applications specified for single mode of 1.25 Gb/s. It operates with +3.3V power supply. The module is intended for single mode fiber, operates at a nominal wavelength of CWDM and complies with Multi-Source Agreement (MSA) Small Form Factor Pluggable (SFP). Each module is integrated digital diagnostics functions via an I²C serial interface (optional).

The module is a duplex LC connector transceiver designed for use in Gigabit Ethernet applications and to provide IEEE-802.3z compliant link for 1.25Gb/s long reach applications. The characteristics are performed in accordance with ITU-T G.694.2 and G.695.

EMC

Most equipment utilizing high-speed transceivers will be required to meet the following requirements:

- 1) FCC in the United States
- 2) CENELEC EN55022 (CISPR 22) in Europe

To assist the customer in managing the overall equipment EMC performance, the transceivers have been designed to satisfy FCC class B limits and provide good immunity to radio-frequency electromagnetic fields.

Eye Safety

The transceivers have been designed to meet Class 1 eye safety and comply with EN 60825-1.

1.25 Gigabit Ethernet-Single Mode Transceiver



Product Information

Model Number	Wavelength	Latch Color	Operating Temperature & Monitor Function	Distance	Output Power	Sensitivity
AB-GLC-C47-ZX	1470 nm	Gray	0~70 °C	80 km	0 ~ +5 dBm	≤-24 dBm
AB-GLC-C49-ZX	1490 nm	Violet				
AB-GLC-C51-ZX	1510 nm	Blue				
AB-GLC-C53-ZX	1530 nm	Green				
AB-GLC-C55-ZX	1550 nm	Yellow				
AB-GLC-C57-ZX	1570 nm	Orange				
AB-GLC-C59-ZX	1590 nm	Red				
AB-GLC-C61-ZX	1610 nm	Brown				
AB-GLC-C47-ZX-D	1470 nm	Gray	0~70 °C with DOM	80 km	0 ~ +5 dBm	≤-24 dBm
AB-GLC-C49-ZX-D	1490 nm	Violet				
AB-GLC-C51-ZX-D	1510 nm	Blue				
AB-GLC-C53-ZX-D	1530 nm	Green				
AB-GLC-C55-ZX-D	1550 nm	Yellow				
AB-GLC-C57-ZX-D	1570 nm	Orange				
AB-GLC-C59-ZX-D	1590 nm	Red				
AB-GLC-C61-ZX-D	1610 nm	Brown				
AB-GLC-C47-ZX-T	1470 nm	Gray	-40~85 °C	80 km	0 ~ +5 dBm	≤-24 dBm
AB-GLC-C49-ZX-T	1490 nm	Violet				
AB-GLC-C51-ZX-T	1510 nm	Blue				
AB-GLC-C53-ZX-T	1530 nm	Green				
AB-GLC-C55-ZX-T	1550 nm	Yellow				
AB-GLC-C57-ZX-T	1570 nm	Orange				
AB-GLC-C59-ZX-T	1590 nm	Red				
AB-GLC-C61-ZX-T	1610 nm	Brown				
AB-GLC-C47-ZX-DT	1470 nm	Gray	-40~85 °C with DOM	80 km	0 ~ +5 dBm	≤-24 dBm
AB-GLC-C49-ZX-DT	1490 nm	Violet				
AB-GLC-C51-ZX-DT	1510 nm	Blue				
AB-GLC-C53-ZX-DT	1530 nm	Green				
AB-GLC-C55-ZX-DT	1550 nm	Yellow				
AB-GLC-C57-ZX-DT	1570 nm	Orange				
AB-GLC-C59-ZX-DT	1590 nm	Red				
AB-GLC-C61-ZX-DT	1610 nm	Brown				

ABSOLUTE MAX RATINGS

PARAMETER	SYMBOL	MIN	MAX	UNIT	NOTE
Storage Temperature	T _S	-40	85	°C	
Supply Voltage	V _{CC}	0	6	V	
Data Input Voltage	---	0	V _{CC}	V	
Supply Current	I _S		300	mA	

OPERATING CONDITIONS

PARAMETER	SYMBOL	MIN.	TYP.	MAX.	UNIT	NOTE
Supply Voltage	V _{CC}	3.1		3.5	V	
Data Input Voltage Swing	V _{ID}	300		1860	mV	

1.25 Gigabit Ethernet-Single Mode Transceiver



ELECTRICAL CHARACTERISTICS

PARAMETER	SYMBOL	MIN	MAX	UNIT	NOTE
Transmitter					
Transmitter Supply Current	I_{CCT}		200	mA	
Tx Disable Input Voltage - Low	V_{IL}	0	0.8	V	
Tx Disable Input Voltage - High	V_{IH}	2.0	V_{CC}	V	
Tx Fault Output Voltage - Low	V_{OL}	0	0.8	V	
Tx Fault Output Voltage - High	V_{OH}	2.0	V_{CC}	V	
Receiver					
Receiver Supply Current	I_{CCR}		100	mA	
Receiver Data Output Differential Voltage	V_{OD}	0.4	1.3	V	
Rx LOS Output Voltage - Low	V_{OL}	0	0.8	V	
Rx LOS Output Voltage - High	V_{OH}	2.0	V_{CC}	V	
MOD_DEF (1) , MOD_DEF (2) - Low	V_{IL}	-0.6	$V_{\text{CC}} \times 0.3$	V	
MOD_DEF (1) , MOD_DEF (2) - High	V_{IH}	$V_{\text{CC}} \times 0.7$	$V_{\text{CC}} + 0.5$	V	

TRANSMITTER ELECTRO-OPTICAL CHARACTERISTICS

PARAMETER	SYMBOL	MIN	TYP.	MAX	UNIT	NOTE	
Optical Output Power	P_{O}	0		5	dBm	1	
Extinction Ratio	ER	9			dB		
Center Wavelength	λ_{c}	1464.5	1470	1477.5	nm		
		1484.5	1490	1497.5			
		1504.5	1510	1517.5			
		1524.5	1530	1537.5			
		1544.5	1550	1557.5			
		1564.5	1570	1577.5			
		1584.5	1590	1597.5			
		1604.5	1610	1617.5			
Spectral Width (-20dB)	$\Delta \lambda$			1	nm		
Side Mode Suppression Ratio	SMSR	30			dB		
RIN	RIN			-120	dB/Hz		
Optical Rise time (20%-80%)	t_{r}			260	ps	2	
Optical Fall time (20%-80%)	t_{f}			260	ps	2	
Output Eye		Compliant with IEEE802.3z/D5.0					

RECEIVER ELECTRO-OPTICAL CHARACTERISTICS

PARAMETER	SYMBOL	MIN	TYP.	MAX	UNIT	NOTE
Maximum Input Optical Power	P_{max}	-3			dBm	3
Minimum Input Optical Power	P_{min}			-24	dBm	3
Operating Wavelength	λ	1260		1620	nm	
Optical Return Loss	ORL	12			dB	
Receiver Electrical 3dB Upper Cutoff Frequency	---			1500	MHz	
LOS of Signal - Asserted	P_{A}	-35			dBm	
LOS of Signal - Deasserted	P_{D}			-23	dBm	
Loss of Signal -Hysterisis	$P_{\text{D}} - P_{\text{A}}$	0.5			dB	

Notes:

1. Measured average power coupled into 9/125 μ m single mode fiber.
2. These are 20-80% values.
3. Measured with 2^7-1 PRBS at BER< 10^{-12}

1.25 Gigabit Ethernet-Single Mode Transceiver



TIMING CHARACTERISTICS

PARAMETER	SYMBOL	MIN	TYP.	MAX	UNIT	NOTE
TX_DISABLE Assert Time	t _{off}			10	μs	
TX_DISABLE Negate Time	t _{on}			1	ms	
Time to initialize, include reset of TX_FAULT	t _{init}			300	ms	
TX_FAULT from fault to assertion	t _{fault}			100	μs	
TX_DISABLE time to start reset	t _{reset}	10			μs	
Receiver Loss of Signal Assert Time (off to on)	t _{A,RX LOS}			100	μs	
Receiver Loss of Signal Assert Time (on to off)	t _{D,RX LOS}			100	μs	

BLOCK DIAGRAM OF TRANSCEIVER

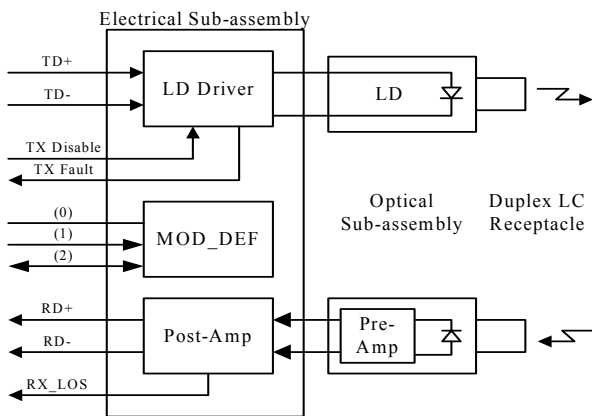

PIN OUT DIAGRAM OF TRANSCEIVER

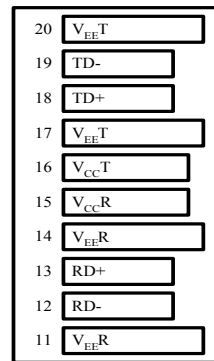

Top of Board

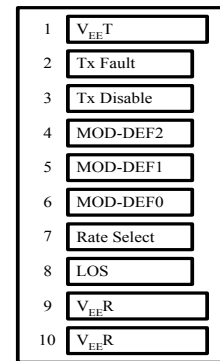

Bottom of Board (As Viewed through Top of Board)

PIN OUT TABLE

Pin	Symbol	Functional Description
1	VeeT	Transmitter Ground
2	TX Fault	Transmitter Fault Indication
3	TX Disable	Transmitter Disable – Module disables on high or open
4	MOD-DEF(2)	Module Definition 2 – Two wire serial ID interface
5	MOD-DEF(1)	Module Definition 1 – Two wire serial ID interface
6	MOD-DEF(0)	Module Definition 0 – Grounded in module
7	Rate Select	Not Connected
8	LOS	Loss of Signal
9	VeeR	Receiver Ground
10	VeeR	Receiver Ground
11	VeeR	Receiver Ground
12	RD-	Inverse Received Data Out
13	RD+	Received Data Out
14	VeeR	Receiver Ground
15	VccR	Receiver Power
16	VccT	Transmitter Power
17	VeeT	Transmitter Ground
18	TD+	Transmitter Data In
19	TD-	Inverse Transmitter Data In
20	VeeT	Transmitter Ground

1.25 Gigabit Ethernet-Single Mode Transceiver



RECOMMENDED CIRCUIT SCHEMATIC

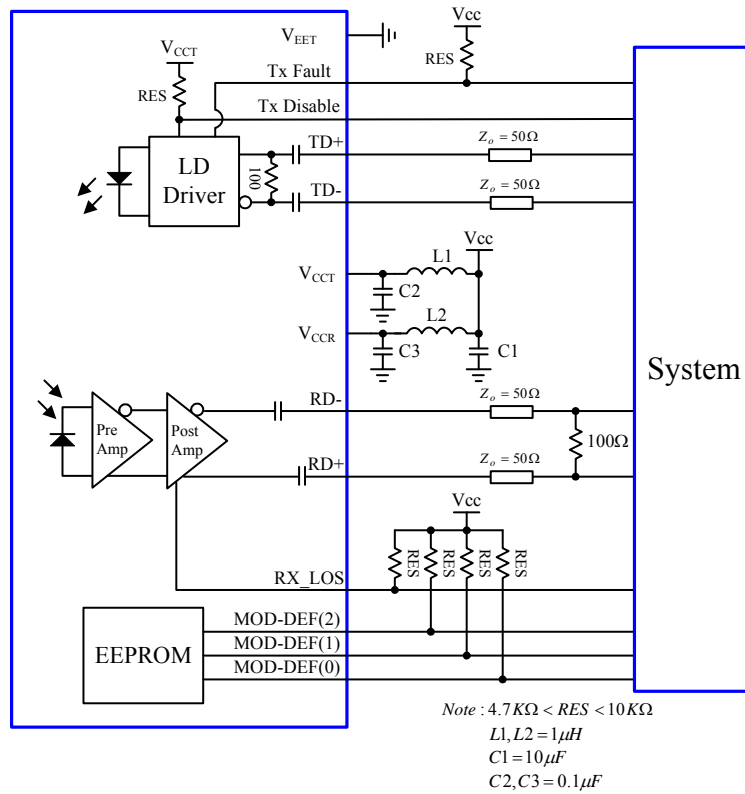

MECHANICAL DIMENSIONS

Units in mm

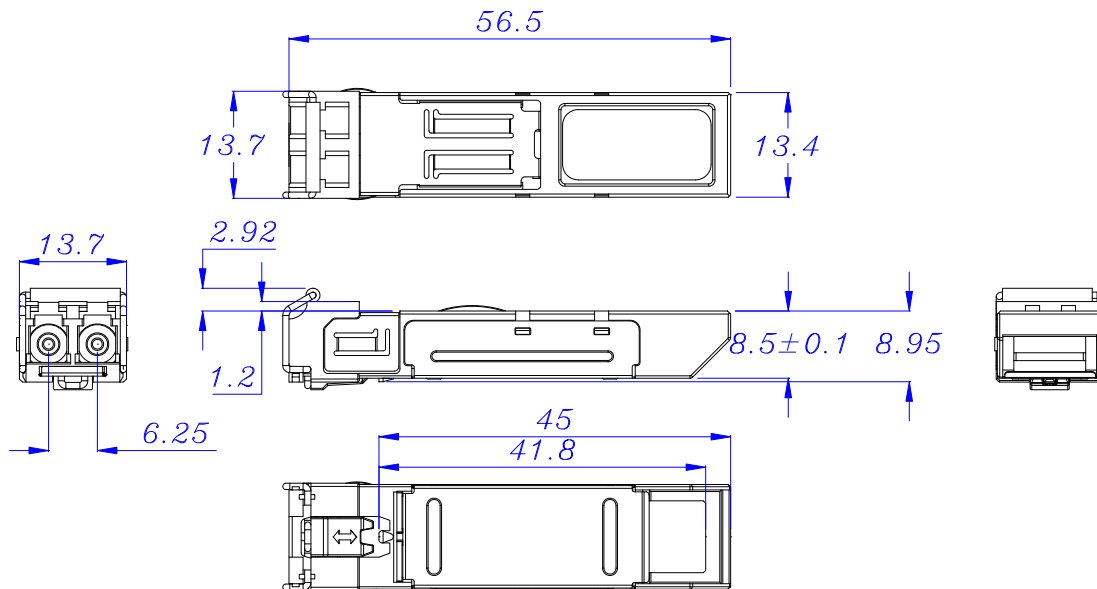

All dimensions are $\pm 0.2\text{mm}$ unless otherwise specified.

Claim:

ACC Systems Oy reserves the right to make changes in the specification described hereinafter without prior notice.