

1.25 Gigabit Ethernet-Multimode Transceiver

SFP, Duplex LC Connector, 850nm VCSEL for Multimode Fiber, RoHS Compliant

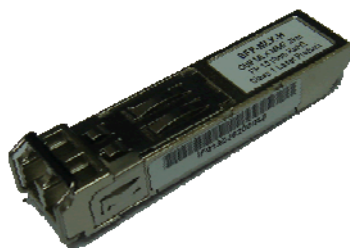

Applications

- Gigabit Ethernet Links
- Fibre Channel Links at 1.06 Gbps
- High Speed Backplane Interconnects
- Switched Backbones

Features

- 850nm VCSEL
- Data Rate: 1.25Gbps, NRZ
- Single +3.3V Power Supply
- RoHS Compliant and Lead-free
- AC/AC Differential Electrical Interface
- Compliant with Multi-Source Agreement (MSA) Small Form Factor Pluggable (SFP)
- Compliant with SFF-8472 Digital Diagnostic Monitoring Interface (optional)
- Duplex LC Connector
- Compliance with specifications for IEEE-802.3z Gigabit Ethernet at 1.25 Gbps
- Compliance with ANSI specifications for Fibre Channel applications at 1.06 Gbps
- Eye Safety
Designed to meet Laser Class 1 comply with EN60825-1

Description

The AB-GLC-SX-MM-x series from ACC Systems Oy is the high performance and cost-effective module for serial optical data communication applications specified for multimode of 1.25 Gb/s. It operates with +3.3V power supply. The module is intended for multimode fiber, operates at a nominal wavelength of 850nm and complies with Multi-Source Agreement (MSA) Small Form Factor Pluggable (SFP). Each module is integrated digital diagnostics functions via an I²C serial interface (optional).

The module is a duplex LC connector transceiver designed for use in Gigabit Ethernet applications and to provide IEEE-802.3z compliant link for 1.25Gb/s short reach applications. The characteristics are performed in accordance with Telcordia Specification GR-468-CORE.

EMC

Most equipment utilizing high-speed transceivers will be required to meet the following requirements:

- 1) FCC in the United States
- 2) CENELEC EN55022 (CISPR 22) in Europe

To assist the customer in managing the overall equipment EMC performance, the transceivers have been designed to satisfy FCC class B limits and provide good immunity to radio-frequency electromagnetic fields.

Eye Safety

The transceivers have been designed to meet Class 1 eye safety and comply with EN 60825-1.

1.25 Gigabit Ethernet-Multimode Transceiver



Product Information

Model Number	Operating Temperature & Monitor Function	LD Type & Wavelength	Output Power	Sensitivity	Distance
<i>AB-GLC-SX-MM</i>	<i>0~70 °C</i>	VCSEL 850 nm	-9.5 ~ -4 dBm	≤ -17 dBm	550 m(50/125 μm) 275 m(62.5/125 μm))
<i>AB-GLC-SX-MM-D</i>	<i>0~70 °C with DOM</i>				
<i>AB-GLC-SX-MM-T</i>	<i>-40~85 °C</i>				
<i>AB-GLC-SX-MM-DT</i>	<i>-40~85 °C with DOM</i>				

ABSOLUTE MAX RATINGS

PARAMETER	SYMBOL	MIN	MAX	UNIT	NOTE
Storage Temperature	T _S	-40	85	°C	
Supply Voltage	V _{CC}	0	6	V	
Supply Current	I _S		240	mA	

OPERATING CONDITIONS

PARAMETER	SYMBOL	MIN.	TYP.	MAX.	UNIT	NOTE
Supply Voltage	V _{CC}	3.1		3.5	V	
Data Input Voltage Swing	V _{ID}	400		1660	mV	

ELECTRICAL CHARACTERISTICS

PARAMETER	SYMBOL	MIN	MAX	UNIT	NOTE
Transmitter					
Transmitter Supply Current	I _{CC} T		140	mA	
Tx Disable Input Voltage - Low	V _{IL}	0	0.8	V	
Tx Disable Input Voltage - High	V _{IH}	2.0	V _{CC}	V	
Tx Fault Output Voltage - Low	V _{OL}	0	0.8	V	
Tx Fault Output Voltage - High	V _{OH}	2.0	V _{CC}	V	
Receiver					
Receiver Supply Current	I _{CC} R		100	mA	
Receiver Data Output Differential Voltage	V _{OD}	0.4	1.3	V	
Rx LOS Output Voltage - Low	V _{OL}	0	0.8	V	
Rx LOS Output Voltage - High	V _{OH}	2.0	V _{CC}	V	
MOD_DEF (1) , MOD_DEF (2) - Low	V _{IL}	-0.6	V _{CC} × 0.3	V	
MOD_DEF (1) , MOD_DEF (2) - High	V _{IH}	V _{CC} × 0.7	V _{CC} + 0.5	V	

TRANSMITTER ELECTRO-OPTICAL CHARACTERISTICS

PARAMETER	SYMBOL	MIN	TYP.	MAX	UNIT	NOTE
Optical Output Power	P _o	-9.5		-4	dBm	1
Extinction Ratio	ER	9			dB	
Center Wavelength	λ _c	830	850	860	nm	
Spectral Width (RMS)	Δλ			0.85	nm	
RIN	RIN			-117	dB/Hz	
Coupled Power Ratio	CPR	9			dB	2
Optical Rise time (20%-80%)	t _r			260	ps	3
Optical Fall time (20%-80%)	t _f			260	ps	3
Output Eye		Compliant with IEEE802.3z/D5.0				

1.25 Gigabit Ethernet-Multimode Transceiver

RECEIVER ELECTRO-OPTICAL CHARACTERISTICS

PARAMETER	SYMBOL	MIN	TYP.	MAX	UNIT	NOTE
Maximum Input Optical Power	P_{max}	-3			dBm	4
Minimum Input Optical Power	P_{min}			-17	dBm	4
Operating Wavelength	λ	770		860	nm	
Optical Return Loss	ORL	12			dB	
Receiver Electrical 3dB Upper Cutoff Frequency	---			1500	MHz	
LOS of Signal - Asserted	P_A	-30			dBm	
LOS of Signal - Deasserted	P_D			-16	dBm	
Loss of Signal -Hysterisis	$P_D - P_A$	0.5			dB	

Notes:

1. Measured average power coupled into 62.5/125 μ m, 0.275 NA or 50/125 μ m, 0.2 NA graded index multimode Fiber.
2. CPR is measured in accordance with EIA/TIA-526-14A as referenced in IEEE 802.3 section 38.6.10.
3. These are 20-80% values.
4. Measured with 2^7-1 PRBS at BER< 10^{-12}

TIMING CHARACTERISTICS

PARAMETER	SYMBOL	MIN	TYP.	MAX	UNIT	NOTE
TX_DISABLE Assert Time	t_{off}			10	μ s	
TX_DISABLE Negate Time	t_{on}			1	ms	
Time to initialize, include reset of TX_FAULT	t_{init}			300	ms	
TX_FAULT from fault to assertion	t_{fault}			100	μ s	
TX_DISABLE time to start reset	t_{reset}	10			μ s	
Receiver Loss of Signal Assert Time (off to on)	t_{A,RX_LOS}			100	μ s	
Receiver Loss of Signal Assert Time (on to off)	t_{D,RX_LOS}			100	μ s	

BLOCK DIAGRAM OF TRANSCEIVER

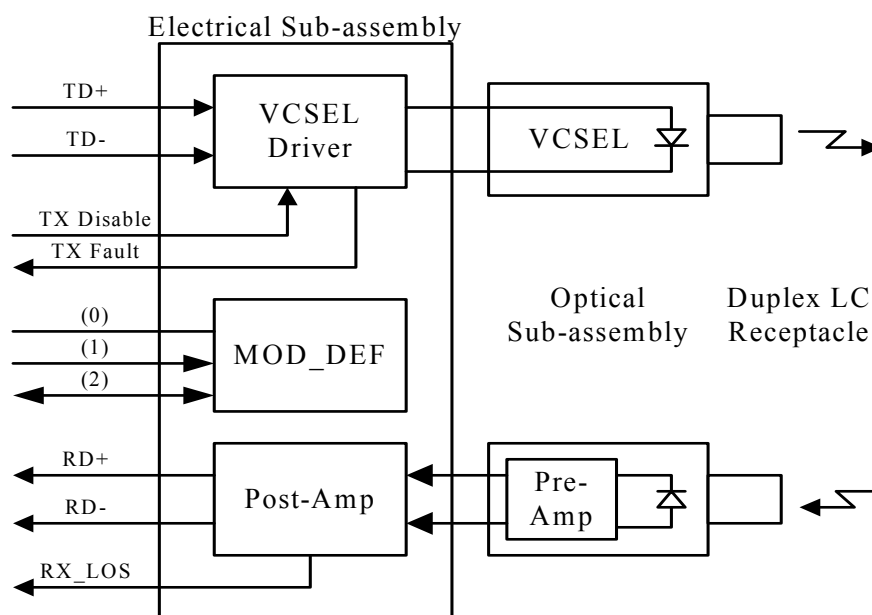

1.25 Gigabit Ethernet-Multimode Transceiver

PIN OUT DIAGRAM OF TRANSCEIVER

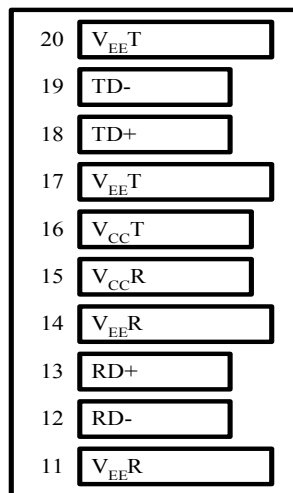

Top of Board

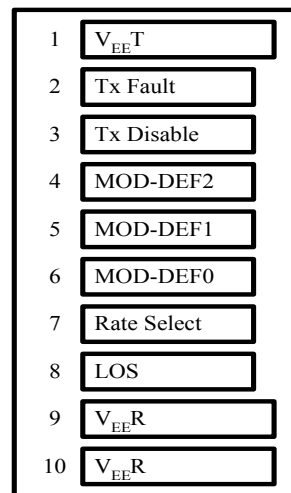

Bottom of Board (As Viewed through Top of Board)

PIN OUT TABLE

Pin	Symbol	Functional Description
1	VeeT	Transmitter Ground
2	TX Fault	Transmitter Fault Indication
3	TX Disable	Transmitter Disable – Module disables on high or open
4	MOD-DEF(2)	Module Definition 2 – Two wire serial ID interface
5	MOD-DEF(1)	Module Definition 1 – Two wire serial ID interface
6	MOD-DEF(0)	Module Definition 0 – Grounded in module
7	Rate Select	Not Connected
8	LOS	Loss of Signal
9	VeeR	Receiver Ground
10	VeeR	Receiver Ground
11	VeeR	Receiver Ground
12	RD-	Inverse Received Data Out
13	RD+	Received Data Out
14	VeeR	Receiver Ground
15	VccR	Receiver Power
16	VccT	Transmitter Power
17	VeeT	Transmitter Ground
18	TD+	Transmitter Data In
19	TD-	Inverse Transmitter Data In
20	VeeT	Transmitter Ground

1.25 Gigabit Ethernet-Multimode Transceiver

RECOMMENDED CIRCUIT SCHEMATIC

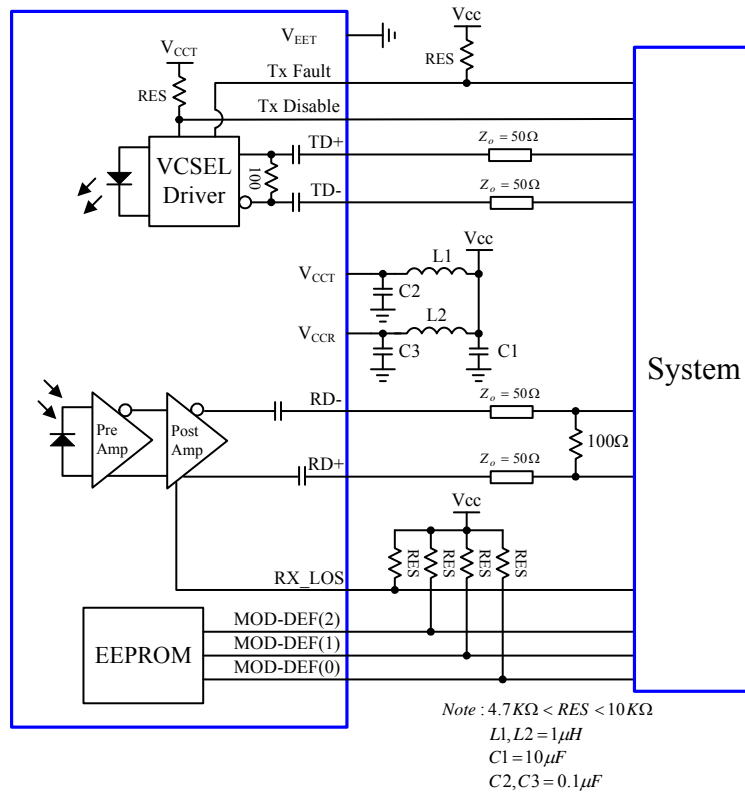

MECHANICAL DIMENSIONS

Units in mm

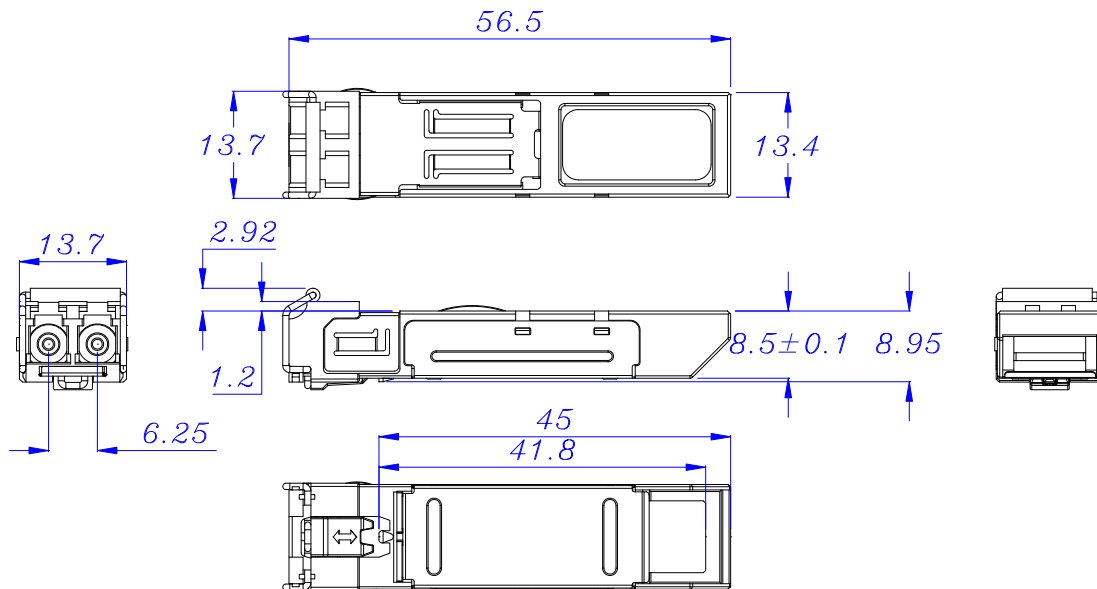

All dimensions are $\pm 0.2\text{mm}$ unless otherwise specified.

Claim:

ACC Systems Oy reserves the right to make changes in the specification described hereinafter without prior notice.