

1.25 Gigabit Ethernet-Single Mode Transceiver



GBIC, Duplex SC Connector, 1310nm DFB LD for Single Mode Fiber, RoHS Compliant



Features

- 1310nm DFB LD
- Data Rate: 1.25Gbps, NRZ
- Single +3.3V/5V Power Supply
- RoHS Compliant and Lead-free
- AC/AC Differential Electrical Interface
- Compliant with Gigabit Interface Converter (GBIC)
- Duplex SC Connector
- Compliance with specifications for IEEE-802.3z Gigabit Ethernet at 1.25 Gbps
- Compliance with ANSI specifications for Fibre Channel applications at 1.06 Gbps
- Eye Safety
Designed to meet Laser Class 1 comply with EN60825-1

Applications

- Gigabit Ethernet Links
- Fibre Channel Links at 1.06 Gbps
- High Speed Backplane Interconnects
- Switched Backbones

Description

The AB-GSC-LHX-SM-x series from ACC Systems Oy is a high performance and cost-effective module for serial optical data communication applications specified for single mode of 1.25 Gb/s. It operates with +3.3/5V power supply. The module is intended for single-mode fiber, operates at a nominal wavelength of 1310nm and complies with Gigabit Interface Converter (GBIC). Each module consists of a transmitter optical subassembly, a receiver optical subassembly and an electrical subassembly. All of them are housed in a metal package and the combination produces a reliable component.

The module is a duplex SC connector transceiver designed for use in Gigabit Ethernet applications and to provide IEEE-802.3z compliant link for 1.25Gb/s long reach applications. The characteristics are performed in accordance with Telcordia Specification GR-468-CORE.

EMC

Most equipment utilizing high-speed transceivers will be required to meet the following requirements:

- 1) FCC in the United States
- 2) CENELEC EN55022 (CISPR 22) in Europe

To assist the customer in managing the overall equipment EMC performance, the transceivers have been designed to satisfy FCC class B limits and provide good immunity to radio-frequency electromagnetic fields.

Eye Safety

The transceivers have been designed to meet Class 1 eye safety and comply with EN 60825-1.

1.25 Gigabit Ethernet-Single Mode Transceiver



Product Information

| Model Number | Operating Temperature | LD Type & Wavelength | Output Power | Sensitivity | Distance |
|-----------------|-----------------------|----------------------|--------------|-------------|----------|
| AB-GSC-LHX-SM | 0~70 °C | DFB 1310nm | -3 ~ +2 dBm | ≤-23 dBm | 40 km |
| AB-GSC-LHX-SM-T | -40~85°C | | | | |

ABSOLUTE MAX RATINGS

| PARAMETER | SYMBOL | MIN | MAX | UNIT | NOTE |
|---------------------|-----------------|-----|-----------------|------|------|
| Storage Temperature | T _S | -40 | 85 | °C | |
| Supply Voltage | V _{CC} | 0 | 6 | V | |
| Data Input Voltage | --- | 0 | V _{CC} | V | |
| Supply Current | I _S | | 300 | mA | |

OPERATING CONDITIONS

| PARAMETER | SYMBOL | MIN. | TYP. | MAX. | UNIT | NOTE |
|--------------------------|-----------------|------|------|------|------|------|
| Supply Voltage | V _{CC} | 3.10 | | 5.25 | V | |
| Data Input Voltage Swing | V _{ID} | 300 | | 1860 | mV | |

ELECTRICAL CHARACTERISTICS

| PARAMETER | SYMBOL | MIN | MAX | UNIT | NOTE |
|---|-------------------|-----------------------|-----------------------|------|------|
| Transmitter | | | | | |
| Transmitter Supply Current | I _{CC} T | | 200 | mA | |
| Tx_Disable Input Voltage - Low | V _{IL} | 0 | 0.8 | V | |
| Tx_Disable Input Voltage - High | V _{IH} | 2.0 | V _{CC} | V | |
| Tx_Fault Output Voltage - Low | V _{OL} | 0 | 0.8 | V | |
| Tx_Fault Output Voltage - High | V _{OH} | 2.0 | V _{CC} | V | |
| Receiver | | | | | |
| Receiver Supply Current | I _{CC} R | | 100 | mA | |
| Receiver Data Output Differential Voltage | V _{OD} | 0.4 | 1.3 | V | |
| Rx_LOS Output Voltage - Low | V _{OL} | 0 | 0.8 | V | |
| Rx_LOS Output Voltage - High | V _{OH} | 2.0 | V _{CC} | V | |
| MOD_DEF (1) , MOD_DEF (2) - Low | V _{IL} | -0.6 | V _{CC} × 0.3 | V | |
| MOD_DEF (1) , MOD_DEF (2) - High | V _{IH} | V _{CC} × 0.7 | V _{CC} + 0.5 | V | |

TRANSMITTER ELECTRO-OPTICAL CHARACTERISTICS

| PARAMETER | SYMBOL | MIN | TYP. | MAX | UNIT | NOTE |
|-----------------------------|----------------|--------------------------------|------|------|-------|------|
| Optical Output Power | P _o | -3 | | 2 | dBm | 1 |
| Extinction Ratio | ER | 9 | | | dB | |
| Center Wavelength | λ _c | 1290 | 1310 | 1325 | nm | |
| Spectral Width (-20dB) | Δ λ | | | 1 | nm | |
| Side Mode Suppression Ratio | SMSR | 30 | | | dB | |
| RIN | RIN | | | -117 | dB/Hz | |
| Optical Rise time (20%-80%) | t _r | | | 260 | ps | 2 |
| Optical Fall time (20%-80%) | t _f | | | 260 | ps | 2 |
| Output Eye | | Compliant with IEEE802.3z/D5.0 | | | | |

1.25 Gigabit Ethernet-Single Mode Transceiver

RECEIVER ELECTRO-OPTICAL CHARACTERISTICS

| PARAMETER | SYMBOL | MIN | TYP. | MAX | UNIT | NOTE |
|--|-------------|------|------|------|------|------|
| Maximum Input Optical Power | P_{max} | -3 | | | dBm | 3 |
| Minimum Input Optical Power | P_{min} | | | -23 | dBm | 3 |
| Operating Wavelength | λ | 1100 | | 1600 | nm | |
| Optical Return Loss | ORL | 12 | | | dB | |
| Receiver Electrical 3dB Upper Cutoff Frequency | --- | | | 1500 | MHz | |
| LOS of Signal - Asserted | P_A | -35 | | | dBm | |
| LOS of Signal - Deasserted | P_D | | | -23 | dBm | |
| Loss of Signal -Hysterisis | $P_D - P_A$ | 0.5 | | | dB | |

Notes:

1. Measured average power coupled into 9/125 μ m single mode fiber.
2. These are 20-80% values.
3. Measured with 2^7-1 PRBS at BER< 10^{-12}

TIMING CHARACTERISTICS

| PARAMETER | SYMBOL | MIN | TYP. | MAX | UNIT | NOTE |
|---|-----------------|-----|------|-----|---------|------|
| TX_DISABLE Assert Time | t_{off} | | | 10 | μ s | |
| TX_DISABLE Negate Time | t_{on} | | | 1 | ms | |
| Time to initialize, include reset of TX_FAULT | t_{init} | | | 300 | ms | |
| TX_FAULT from fault to assertion | t_{fault} | | | 100 | μ s | |
| TX_DISABLE time to start reset | t_{reset} | 10 | | | μ s | |
| Receiver Loss of Signal Assert Time (off to on) | t_{A,RX_LOS} | | | 100 | μ s | |
| Receiver Loss of Signal Assert Time (on to off) | t_{D,RX_LOS} | | | 100 | μ s | |

BLOCK DIAGRAM OF TRANSCEIVER

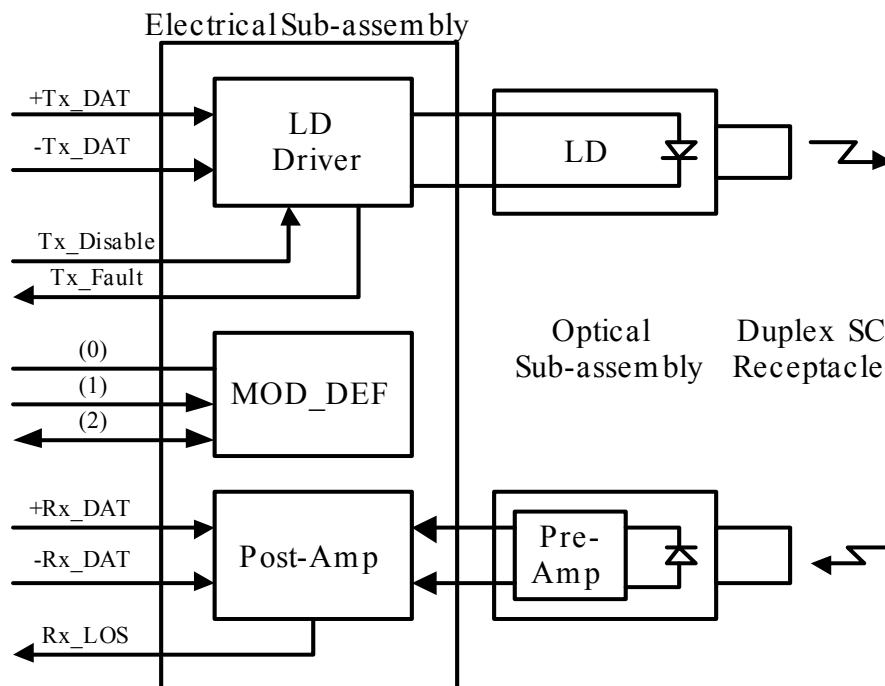

1.25 Gigabit Ethernet-Single Mode Transceiver



PIN OUT DIAGRAM OF TRANSCEIVER

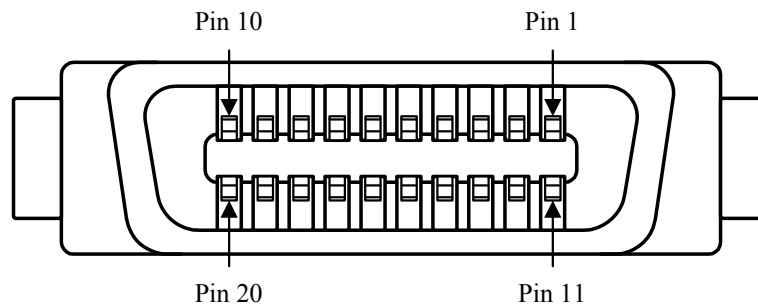

PIN OUT TABLE

| Pin | Symbol | Functional Description |
|-----|-------------------|---|
| 1 | Rx_LOS | Loss of Signal |
| 2 | RGND | Receiver Ground |
| 3 | RGND | Receiver Ground |
| 4 | MOD-DEF(0) | Module Definition 0 – Grounded in module |
| 5 | MOD-DEF(1) | Module Definition 1 – Two wire serial ID interface |
| 6 | MOD-DEF(2) | Module Definition 2 – Two wire serial ID interface |
| 7 | Tx_Disable | Transmitter Disable – Module disables on high or open |
| 8 | TGND | Transmitter Ground |
| 9 | TGND | Transmitter Ground |
| 10 | Tx_Fault | Transmitter Fault Indication |
| 11 | RGND | Receiver Ground |
| 12 | -Rx_DAT | Inverse Received Data Out |
| 13 | +Rx_DAT | Received Data Out |
| 14 | RGND | Receiver Ground |
| 15 | V _{DD} R | Receiver Power |
| 16 | V _{DD} T | Transmitter Power |
| 17 | TGND | Transmitter Ground |
| 18 | +Tx_DAT | Transmitter Data In |
| 19 | -Tx_DAT | Inverse Transmitter Data In |
| 20 | TGND | Transmitter Ground |

1.25 Gigabit Ethernet-Single Mode Transceiver

RECOMMENDED CIRCUIT SCHEMATIC

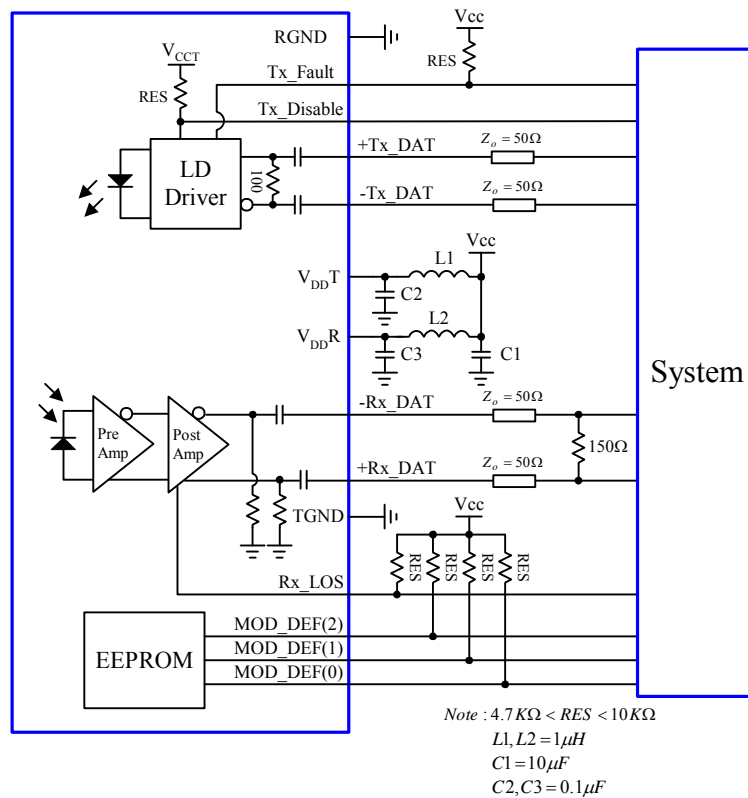

MECHANICAL DIMENSIONS

Units in mm

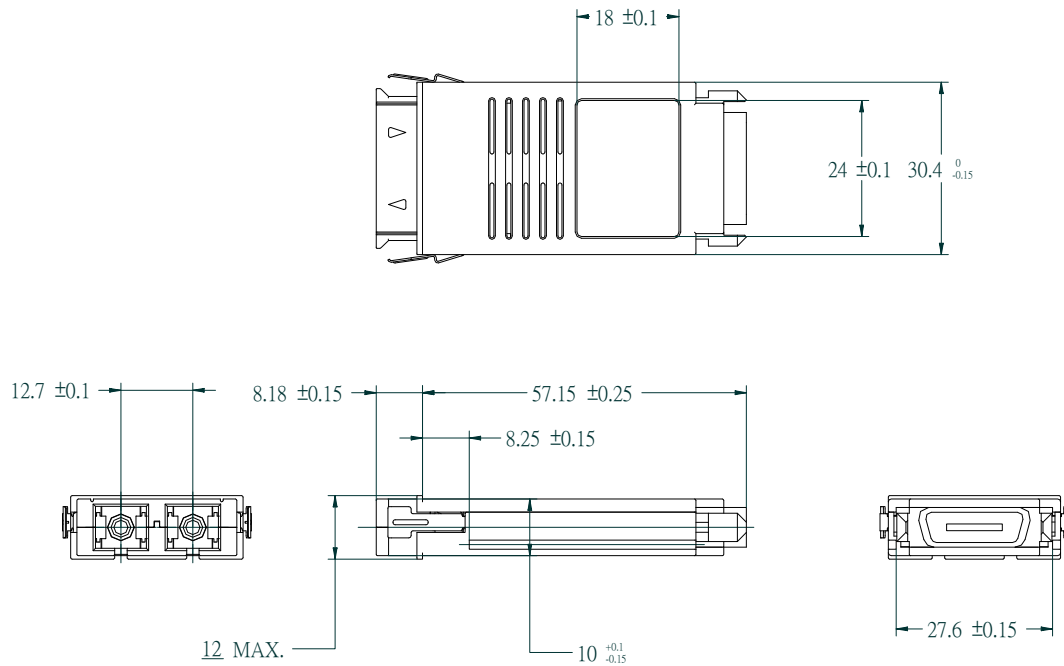

Claim:

ACC Systems Oy reserves the right to make changes in the specification described hereinafter without prior notice.