

10Gb/s Multirate DDMI XFP (XFP LR)
1310nm uncooled DFB with PIN Receiver
10km transmission distance

Feature

- 10Gb/s serial optical interface compliant to 802.3ae
- Uncooled 1310nm DFB transmitter and Pin photodiode receiver
- XFP Mechanical interface with bail latch and hot pluggable
- XFI High Speed Electrical Interface
- 2-wire interface for management and digital diagnostic monitor
- Low Power Consumption, Single +3.3V Power supply
- Operating case temperature: 0 to 70 °C
- All-metal housing for superior EMI performance
- Advanced firmware allow customer system encryption information to be stored in transceiver

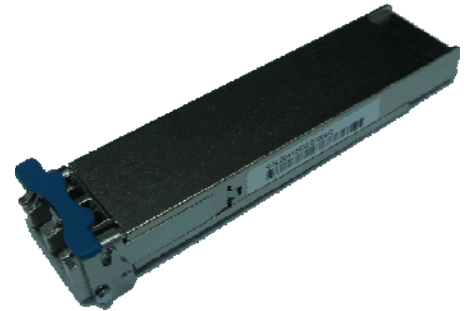

Application

- SONET(OC-192)/SDH(STM64) line card
- 10GBASE-LR (10.3125Gbps)
- 10GBASE-LW (9.953Gbps)

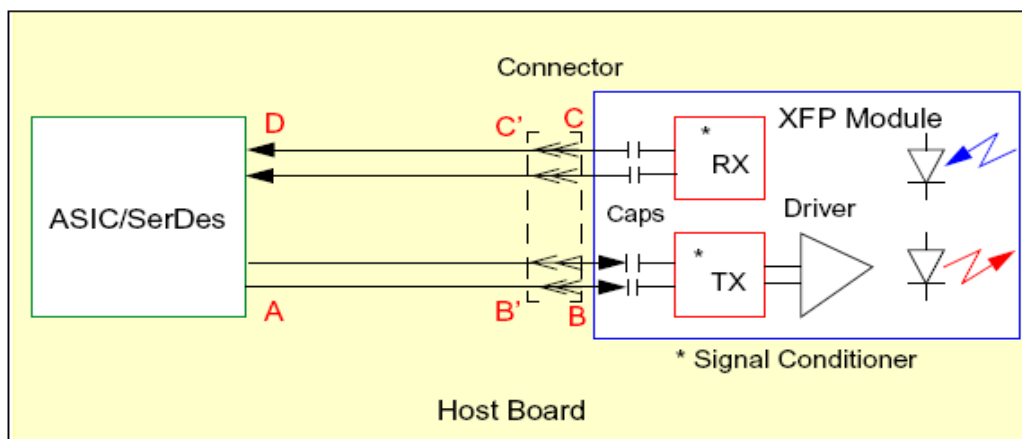

Figure 1: Interface to Host

ACC Systems Oy reserves the right to make changes in the specification described hereinafter without prior notice.



AB-XFP-LR-OC192
Ver. A

10Gb/s Multirate DDMI XFP (XFP LR)
1310nm uncooled DFB with PIN Receiver
10km transmission distance

General Description

The AB-XFP-LR-OC192 is a very compact 10Gb/s optical transceiver module for serial optical communication applications at 10Gb/s. The AB-XFP-LR-OC192 converts a 10Gb/s serial electrical data stream to 10Gb/s optical output signal and a 10Gb/s optical input signal to 10Gb/s serial electrical data streams. The high speed 10Gb/s electrical interface is fully compliant with XFI specification and allows FR4 host PCB trace up to 200mm.

The AB-XFP-LR-OC192 is designed for use in a variety of 10Gb/s SONET/SDH equipment including FEC (9.95Gb/s to 10.7Gb/s) and Ethernet LAN (10.3Gb/s) and WAN (9.95Gb/s) applications. The high performance uncooled 1310nm DFB-LD transmitter and high sensitivity PIN receiver provide superior performance for SONET /SDH and Ethernet applications at up to 10km links. The fully XFP compliant form factor provides hot pluggability, easy optical port upgrades and low EMI emission.

Functional Description

The AB-XFP-LR-OC192 contains a duplex LC connector for the optical interface and a 30-pin connector for the electrical interface. Chart of section 3 shows the functional block diagram of AB-XFP-LR-OC192 Transceiver.

Transmitter Operation

The transceiver module receives 10Gb/s electrical data and transmits the data as an optical signal. The transmitter contains a Clock Data Recovery (CDR) circuit that reduces the jitter of received signal and reshapes the electrical signal before the electrical to optical (E-O) conversion. The optical output power is maintained constant by an automatic power control (APC) circuit. The transmitter output can be turned off by TX disable signal, at TX_DIS pin. When TX_DIS is asserted high, the transmitter is turned off.

Receiver Operation

The received optical signal is converted to serial electrical data signal. The optical receiver contains a CDR circuits that reshapes and retimes an electrical signal before sending out to the XFI channel (i.e. XFP connector and high speed signal traces). The RX_LOS signal indicates insufficient optical power for reliable signal reception at the receiver.

ACC Systems Oy reserves the right to make changes in the specification described hereinafter without prior notice.

10Gb/s Multirate DDMI XFP (XFP LR)
1310nm uncooled DFB with PIN Receiver
10km transmission distance

Management Interface

A 2-wire interface (SCL, SDA) is used for serial ID, digital diagnostics and other control /monitor functions. The address of XFP transceiver is 1010000x. MOD_DESEL signal can be used in order to support multiple XFP modules on the same 2-wire interface bus. Interface is compliant to XFP MSA.

Recommended Electrical Interface to Host

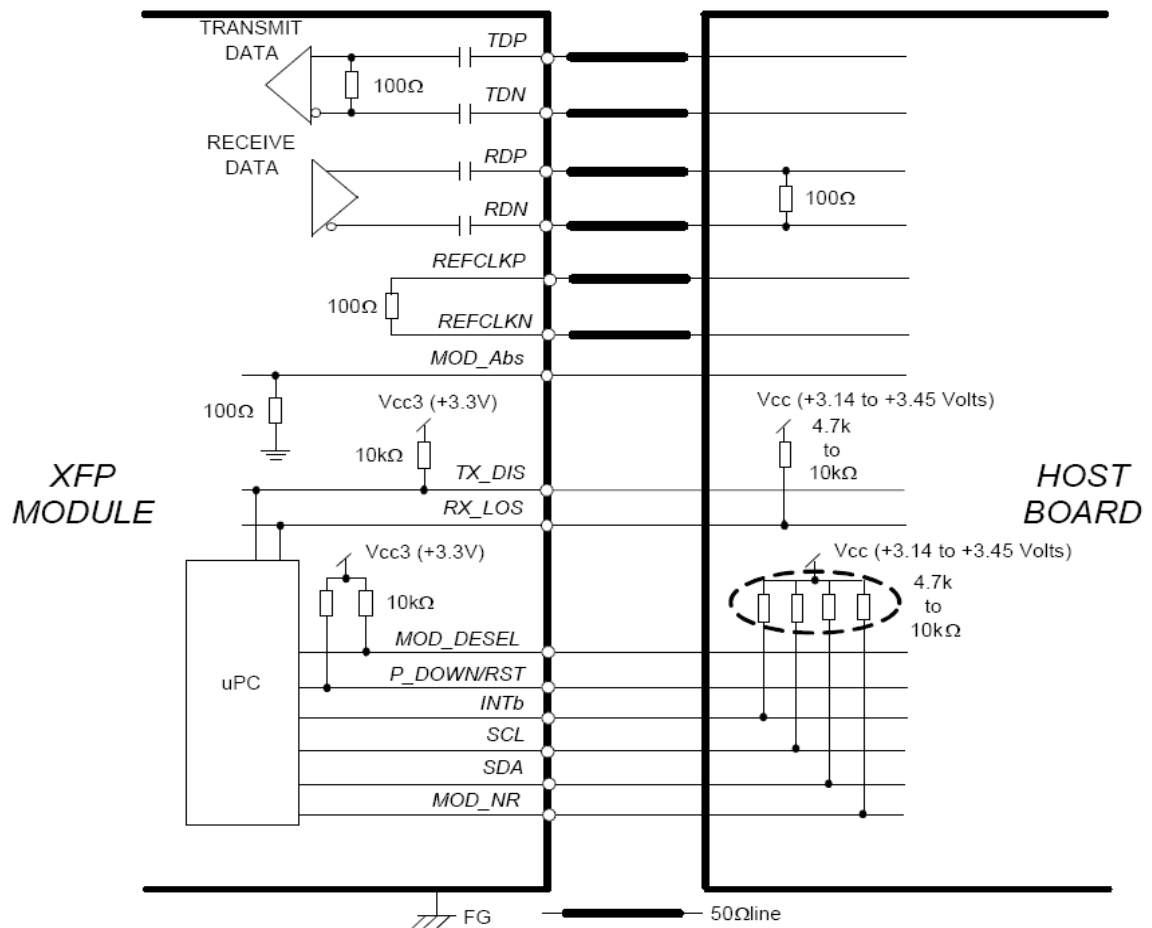

ACC Systems Oy reserves the right to make changes in the specification described hereinafter without prior notice.

10Gb/s Multirate DDMI XFP (XFP LR)
1310nm uncooled DFB with PIN Receiver
10km transmission distance

PIN DEFINITION

The XFP modules are hot-pluggable. Hot pluggable refers to plugging in or unplugging a module while the host board is powered. The XFP host connector is based on a 0.8 mm pitch 30 position right angle connector. Host PCB pin assignment is given by Figure 2 and pin definition are listed in Table 2. All XFP compliance points are defined using this connector. An improved version of this connector will be available from Tyco and possibly from other sources. It is recommended that host systems use the new improved connector for better signal integrity and EMI.

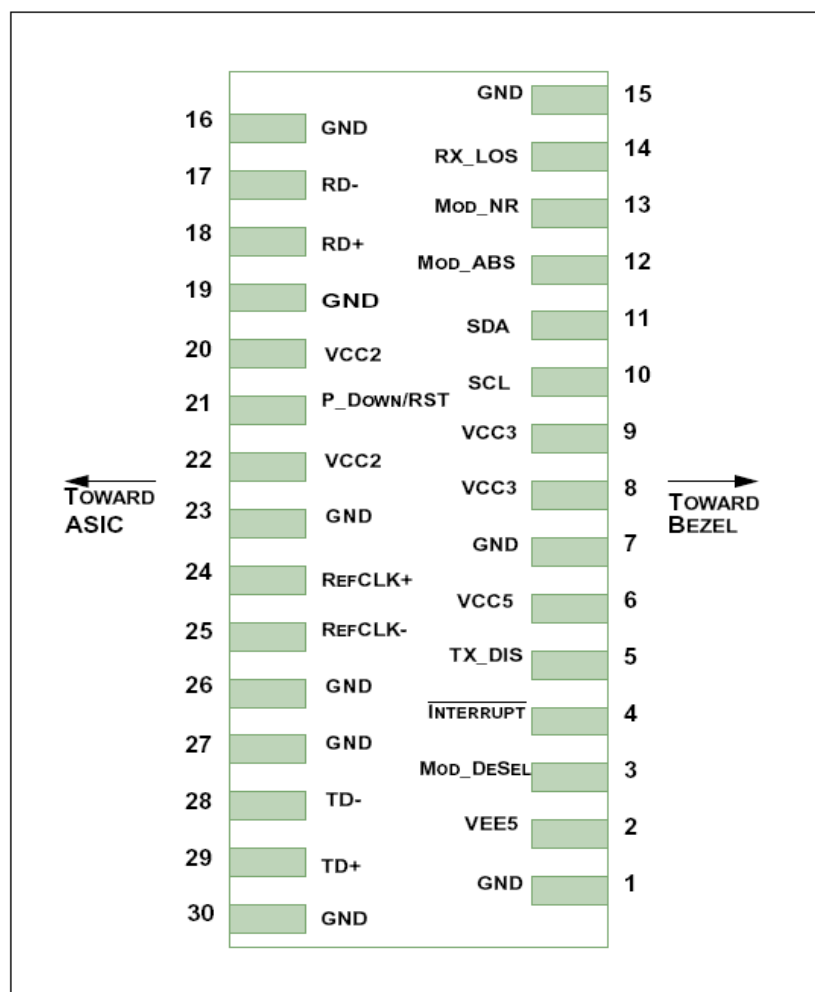

Interface to Host PCB

ACC Systems Oy reserves the right to make changes in the specification described hereinafter without prior notice.



AB-XFP-LR-OC192
Ver. A

10Gb/s Multirate DDMI XFP (XFP LR)
1310nm uncooled DFB with PIN Receiver
10km transmission distance

Pin Descriptions

| Pin# | Name | Logic | Descriptions | Note |
|------|------------|----------|---|-------|
| 1 | GND | | Module Ground | 1 |
| 2 | VEE5 | | 0.2V Power Supply , not in use | 3 |
| 3 | MOD_DESEL | LVTTTL-I | Module De-select; When held Low allows module to respond to 2-wire serial interface | |
| 4 | INTERRUPTb | LVTTTL-O | Indicates presence of an important condition, which can be read over the 2-wire serial interface. This pin is an open collector output and must be pulled up to host_Vcc on the host board. | 2 |
| 5 | TX_DIS | LVTTTL-I | Transmitter Disable; When asserted High, transmitter output is turned off. This pin is pulled up to VCC3 in the module | |
| 6 | VCC5 | | +5V Power Supply, not in use | 3 |
| 7 | GND | | Module Ground | 1 |
| 8 | VCC3 | | +3.3V Power Supply | |
| 9 | VCC3 | | +3.3V Power Supply | |
| 10 | SCL | I/O | 2-wire serial interface clock. Host shall resistor connected to host_Vcc of +3.3V. | 2 |
| 11 | SDA | I/O | 2-wire serial interface data. Host shall use a pull-up resistor connected to host_Vcc of +3.3V. | 2 |
| 12 | MOD_ABS | LVTTTL-O | Indicates Module is not present. Host shall pull up this pin, and grounded in the module. "High" when the XFP module is absent from a host board. | 2 |
| 13 | MOD_NR | LVTTTL-O | Module not ready; When High, Indicates Module Operational Fault. This pin is an open collector and must be pulled to host_Vcc on the host board. | 2,4,5 |
| 14 | RX_LOS | LVTTTL-O | Receiver Loss of Signal; When high, indicates insufficient optical input power to the module. This pin is an open collector and must be pulled to host_Vcc on the host board. | 2 |
| 15 | GND | | Module Ground | |
| 16 | GND | | Module Ground | |
| 17 | RDN | CML-O | Receiver Inverted Data Output; AC coupled inside the module. | |
| 18 | RDP | CML-O | Receiver Non-Inverted Data Output; AC coupled in side the module. | |
| 19 | GND | | Module Ground | 1 |

ACC Systems Oy reserves the right to make changes in the specification described hereinafter without prior notice.



AB-XFP-LR-OC192
Ver. A

10Gb/s Multirate DDMI XFP (XFP LR)
1310nm uncooled DFB with PIN Receiver
10km transmission distance

| Pin# | Name | Logic | Description | Note |
|------|------------|----------|---|------|
| 20 | VCC2 | | +1.8V Power Supply; not in use | 3 |
| 21 | P_DOWN/RST | LVTTTL-I | Power down; When High, module is limited power mode. Low for normal operation. Reset; The falling edge indicates complete reset of the module. This pin is pulled up to VCC3 in the module. | |
| 22 | VCC2 | | +1.8V Power Supply; not in use | 3 |
| 23 | GND | | Module Ground | 1 |
| 24 | REFCLKP | PECL-I | Reference clock Non-Inverted Input; not in use | |
| 25 | REFCLKN | PECL-I | Reference clock Inverted Input; not in use | |
| 26 | GND | | Module Ground | 1 |
| 27 | GND | | Module Ground | 1 |
| 28 | TDN | CML-I | Transmitter Inverted Data Input; AC coupled in side the module. | |
| 29 | TDP | CML-I | Transmitter Non-Inverted Data Input; AC coupled in side the module. | |
| 30 | GND | | Module Ground | 1 |

- *Notes: 1. Module ground pins are isolated from the module case and chassis ground within the module.
2. Shall be pulled up with 4.7k to 10k ohm to a voltage between 3.15V and 3.45V on the host board.
3. Not connected internally.
4. Response time: typ. 20msec (XFP MSA Rev. 4.5 \leq 1msec)
5. MOD_NR = (TX LOL) OR (RX LOL).

ACC Systems Oy reserves the right to make changes in the specification described hereinafter without prior notice.



AB-XFP-LR-OC192
Ver. A

10Gb/s Multirate DDMI XFP (XFP LR)
1310nm uncooled DFB with PIN Receiver
10km transmission distance

Absolute Maximum Ratings

| Parameter | Symbol | Min | Max | Unit | Note |
|---------------------------------------|---------|------|----------|------|------|
| Storage Temperature | Tst | -40 | 85 | degC | |
| Relative Humidity (non-condensation) | RH | - | 85 | % | |
| Operating Case Temperature | Topc | 0 | 70 | degC | 1 |
| Supply Voltage | VCC3 | -0.5 | 3.6 | V | |
| Voltage on LVTTTL Input | Vilvttl | -0.5 | VCC3+0.5 | V | |
| LVTTTL Output Current | Iolvttl | - | 15 | mA | |
| Voltage on Open Collector Output | Voco | 0 | 6 | V | |
| Receiver Input Optical Power(Average) | Mip | - | 3 | dBm | 2 |

*Notes: 1. Ta: -10 to 60degC with 1.5m/s airflow with an additional heat sink.

2. Pin Receiver.

Recommended Operating Conditions and Supply Requirements

| Parameters | Symbol | Min | Max | Unit |
|------------------------------------|--------|-------|-------|------|
| Operating Case Temperature | Topc | 0 | 70 | degC |
| Relative Humidity (non-condensing) | Rhop | - | 85 | % |
| Power Supply Voltage | VCC3 | 3.135 | 3.465 | V |
| Power Supply Current | ICC3 | - | 700 | mA |
| Total Power Consumption | Pd | - | 2.0 | W |

Low Speed Control and Alarm Signals Electrical Interface

| Parameters | Symbol | Min | Max | Units | Note |
|-------------------------------|--------|---------|----------|-------|------|
| XFP Interrupt, Mod_NR, RX_LOS | Vol | 0.0 | 0.4 | V | 1 |
| | Voh | Vcc-0.5 | Vcc+0.3 | | 2 |
| XFP TX_DIS, P_DOWN/RST | Vil | -0.3 | 0.8 | V | 3 |
| | Vih | 2.0 | VCC3+0.3 | | 4 |
| XFP SCL and SDA Output | Vol | 0.0 | 0.4 | V | 1 |
| | Voh | Vcc-0.5 | Vcc+0.3 | | 2 |
| XFP SCL and SDA Input | Vil | -0.3 | VCC3*0.3 | V | 5 |

ACC Systems Oy reserves the right to make changes in the specification described hereinafter without prior notice.



AB-XFP-LR-OC192
Ver. A

10Gb/s Multirate DDMI XFP (XFP LR)
1310nm uncooled DFB with PIN Receiver
10km transmission distance

| | | | | | |
|---|-----|----------|----------|----|---|
| | Vih | VCC3*0.7 | VCC3+0.5 | | 6 |
| Capacitance for XFP SCL and SDA I/O pin | Ci | - | 14 | pF | |
| Total bus capacitive load for SCL and SDA | Cb | - | 100 | pF | 7 |
| | | | 400 | pF | 8 |

*Notes: 1. Pull-up resistor must be connected to host_Vcc on the host board. Iol(max)=3mA

2. Pull-up resistor must be connected to host_Vcc on the host board.
3. Pull-up resistor connected to VCC3 within XFP module. Iil(max)= -10μA.
4. Pull-up resistor connected to VCC3 within XFP module. Iih(max)= 10μA.
5. Pull-up resistor must be connected to host_Vcc on the host board. Iol(max)= -10μA.
6. Pull-up resistor must be connected to host_Vcc on the host board. Iol(max)= 10μA.
7. At 400KHz, 3.0kohms, at 100kHz 8.0kohms max.
8. At 400KHz, 0.8kohms, at 100kHz 2.0kohms max.

Optical Interface

| Transmitter Optical Interface | | | | | | |
|--------------------------------------|--------------------|-------------------------|----------------|------------|-------------|-------------|
| Parameter | Symbol | Min | Typical | Max | Unit | Note |
| Operating Data Rate | - | 9.95 | | 10.70 | Gb/s | 1 |
| Output Center Wavelength | l _{tc} | 1290 | 1310 | 1330 | nm | |
| Spectral Width | dl | - | | 1 | nm | |
| SMSR | SMSR | 30 | | - | dB | |
| Average Output Power | P _o | -8 | | 0 | dBm | 2 |
| Disabled Power | P _{off} | - | | -30 | dBm | 2 |
| Extinction Ratio | ER | 6 | | - | dB | 2 |
| Minimum OMA (10G Ethernet) | OMA | 0.2 | | - | dBm | 3 |
| Minimum OMA-TDP (10G Ethernet) | OMAt _{dp} | -6.2 | | - | dBm | 3 |
| Eye Mask 1 (SONET/SDH) | | GR-253-CORE/ITU-T G.691 | | | | 2 |
| Eye Mask 2 (10G Ethernet) | | IEEE802.3ae | | | | 3 |
| Generation Jitter 1 (20kHz - 80MHz) | | - | | 0.15 | Ulp-p | 2,4 |
| Generation Jitter 2 (4MHz - 80MHz) | | - | | 0.1 | Ulp-p | 2,4 |
| RIN | RIN | - | | -128 | dB/Hz | |
| Optical Path | | | | | | |

ACC Systems Oy reserves the right to make changes in the specification described hereinafter without prior notice.



AB-XFP-LR-OC192
Ver. A

10Gb/s Multirate DDMI XFP (XFP LR)
1310nm uncooled DFB with PIN Receiver
10km transmission distance

| Parameter | Symbol | Min | Typical | Max | Unit | Note |
|---------------------------------------|--------|-------------------------|---------|-------|-------|------|
| Chromatic Dispersion (SONET/SDH) | CD | - | | 6.6 | ps/nm | |
| Operating Distance (10G Ethernet) | | - | | 10 | km | |
| Attenuation (SONET/SDH) | | 0 | | 4 | dB | |
| Channel Insertion Loss (10G Ethernet) | | 0 | | 6 | dB | |
| Maximum DGD (SONET/SDH) | DGD | - | | 30 | ps | |
| Optical Path | | | | | | |
| Parameter | Symbol | Min | Typical | Max | Unit | Note |
| Operating Data Rate | - | 9.95 | | 10.70 | Gb/s | 1 |
| Input Center Wavelength | lrc | 1260 | | 1565 | nm | |
| Overload | Rovl | 0.5 | | - | dBm | |
| Minimum Sensitivity | Pmin | - | -14 | -11 | dBm | 2 |
| Sensitivity in OMA | OMA0 | - | | -12.6 | dBm | 3 |
| Stressed Sensitivity in OMA | OMAst | - | | -10.3 | dBm | 3 |
| RX_LOS Assert Level | RLOSa | -30 | | -25 | dBm | |
| RX_LOS Deassert Level | RLOSd | | | -22 | dBm | |
| RX_LOS Hysteresis | RLOSh | 1 | | 5 | dB | |
| Optical Path Penalty | PN | - | | 1 | dB | 1 |
| Optical Return Loss | ORL | 14 | | - | dB | |
| Jitter Tolerance | JTL | GR-253-CORE/ITU-T G.783 | | | | |

*Notes: 1. Data rate tolerance

- SONET SR-1,10GBASE-LW:typ.+/-20ppm
- 10GBASE-LR: typ.+/-100ppm

2. Measured at 10.3125Gbps,Non-framed PRBS2³¹-1,NRZ

3. Measured by using ACC Systems Oy XFP evaluation board.

ACC Systems Oy reserves the right to make changes in the specification described hereinafter without prior notice.

10Gb/s Multirate DDMI XFP (XFP LR)
1310nm uncooled DFB with PIN Receiver
10km transmission distance

Mechanical Dimensions

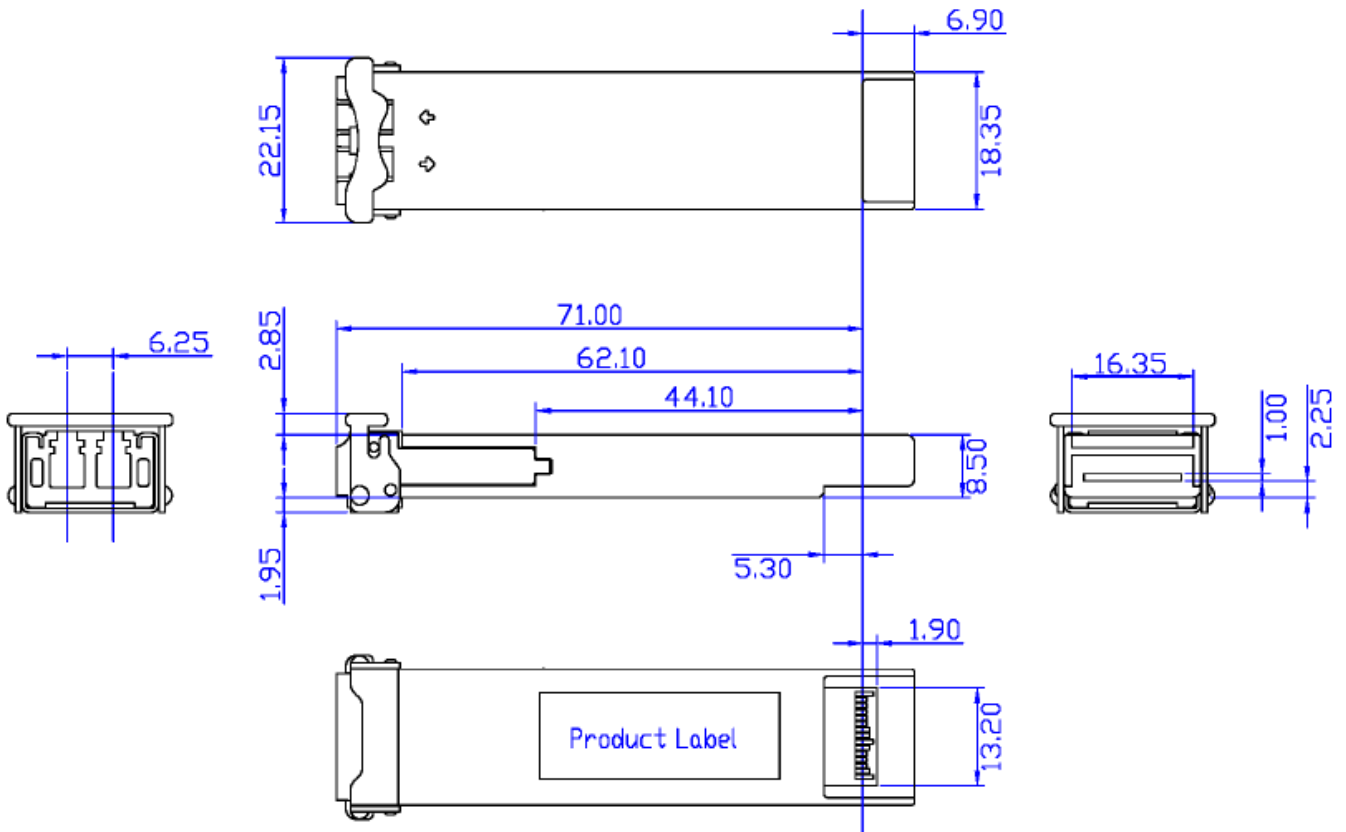

ACC Systems Oy reserves the right to make changes in the specification described hereinafter without prior notice.

10Gb/s Multirate DDMI XFP (XFP LR)
1310nm uncooled DFB with PIN Receiver
10km transmission distance

ESD

This transceiver is specified as ESD threshold 2kV for all electrical input pins, tested per MIL-STD-883, Method 3015.4 /JESD22-A114-A (HBM). However, normal ESD precautions are still required during the handling of this module. This transceiver is shipped in ESD protective packaging. It should be removed from the packaging and handled only in an ESD protected environment.

Safety Information

- All versions of this laser are Class 1 laser products per IEC* 60825-1:2001. Users should observe safety precautions such as those recommended by ANSI** Z136.1-2000, ANSI Z36.2-1997 and IEC 60825-1:2001.
- Caution: use of controls or adjustments or performance of procedures other than those specified herein may result in hazardous radiation exposure.

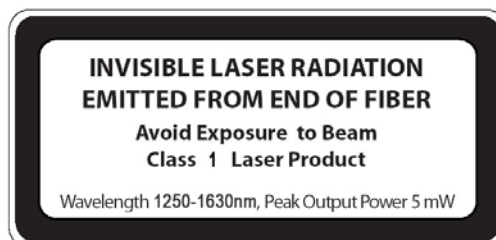

classified in accordance with IEC 60825-1:2001-08

*IEC is a registered trademark of the International Electrotechnical Commission

**ANSI is a registered trademark of the American National Standards Institute

ACC Systems Oy reserves the right to make changes in the specification described hereinafter without prior notice.